

## ADVANCED LINE

### Stainless Steel Air Motors from 20 W / 0.03 Hp up to 1.6 kW / 2.1 Hp

The ADVANCED LINE air motors are particularly suitable for use in the food industry, medical technology, underwater applications and the chemical industry. All airmotors can also be used without lubrication. All external parts (housing and spindle) of our ADVANCED LINE series are made from high quality non corrosive steel. Our air motors are also available in an ATEX conform complete system with integrated holding brakes.

In addition our modular principle enables us to offer low cost customisations for your specific application!

**non corrosive  
sterilisable**

**ATEX conform  
compact**

**oil-free  
sealed  
insensitive to cleaning solvents**

#### High torque motors made from stainless steel:

Our ADVANCED LINE pneumatic motors are also available as high torque motors made from stainless steel. The ideal drive solution for e.g. agitators and industrial mixers.



High torque  
stainless steel motors

small in size but  
extremely high torque

 67-517  
 Nr. 1123063109  
 6bar

 67-517  
 Nr. 1123063109  
 6bar

ATEX conform system: air motor - holding brake - gear

## PRODUCT SPECTRUM OVERVIEW: ADVANCED LINE AIR MOTORS

### Stainless steel motors with integrated planetary gears



The vane motors of the ADVANCED LINE are particularly compact drive solutions for installation in either handheld machines or industrial systems. These top quality stainless steel motors are suitable for the chemical industry, for the paper industry, the pharmaceutical industry, medical technology and also for use in the food industry.

#### Performance classes:

20/30 W	Page 4
80/100 W	Page 6
90/120/170 W	Page 8
100/200/280 W	Page 10
130/300/400	Page 12
300/600/850 W	Page 20
900/1100 W	Page 22
700/1600/2200 W	Page 32

### High torque stainless steel motors



The high torque motors of the ADVANCED LINE are small in size but provide extremely high output. Our high torque motors are also less apt to stall, the stalling torque for e.g. motor type 67X-517 is 600 Nm. These drive solutions are particularly suitable for use in industrial agitators and mixers as used in the paint industry, food industry or pharmaceutical industry.

#### Performance classes:

300/400 W	Page 14
600/850 W	Page 24
900/1100 W	Page 26

### Stainless steel motors with integrated holding brake



Due to their size and design DEPRAG stainless steel motors with integrated holding brake are the optimal choice for use in any application where reliability plays an important role. The integrated holding brake can either be controlled using a separate control lead or via the motor exhaust. If pressure falls the brakes are automatically activated.

The big plus: This innovative complete system is also available with ATEX certification!

#### Performance classes:

300 W	Page 16
100/130/200/300 W	Page 18
300/600/900 W	Page 28
600/900 W	Page 30
700/1600 W	Page 34

## ATEX SPECIFICATION

A =	CE	II 2G Ex h IIC T6 Gb X
		II 2D Ex h IIIC T80 °C Db X
B =	CE	II 2G Ex h IIC T5 Gb X
		II 2D Ex h IIIC T95 °C Db X
C =	CE	II 2G Ex h IIC T4 Gb X
		II 2D Ex h IIIC T130 °C Db X
D =	CE	II 2G Ex h IIC T3 Gb X
		II 2D Ex h IIIC T195 °C Db X

## ADVANTAGES OF ADVANCED LINE AIR MOTORS

### LONG LIFE-SPAN

A wide product range of stainless steel motors, the use of DEPRAG high performance vanes as well as a specific surface coating on our materials all this ensures your motor's long life-span.



Airmotor - gear box - valve: a stainless steel system for the paper industry, sealed stainless steel motors, high performance vanes

### SHORT DELIVERY TIMES

Due to our large amount of in-house production we are able to deliver quickly and flexibly at short notice, even when dealing with smaller quantities.

### APPLICATION CONSULTANCY

Our application engineers will gladly advise you in the selection of the most suitable drive for your application. If you would like to test or replace your existing drive we can check it for you in our innovative performance testing facility.

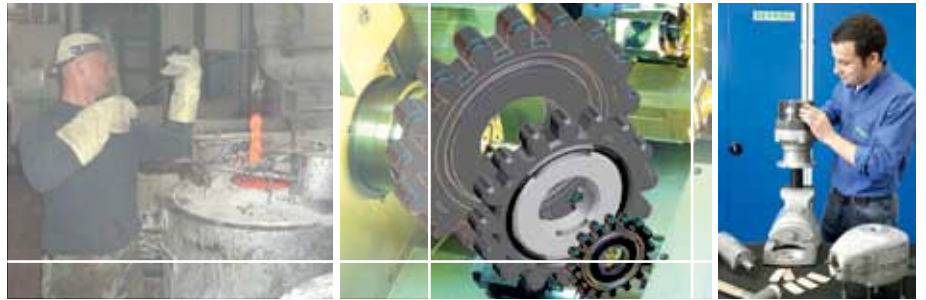

Large amount of in-house production, on-site salt bath heat treatment facility

### WIDE VARIETY AND COMPREHENSIVE RANGE OF ACCESSORIES

Our standard programme is distinguished by its wide variety. All our stainless steel motors are also available with threaded spindle. Additionally due to our modular principle we are able to offer numerous variations to choose from. Do not hesitate to contact us if you have a specific mounting fixture request.



Performance testing facility, professional guidance from our engineers

## 20/30 W ADVANCED LINE AIR MOTOR

Motor size 0		reversible				
Series 67X-	Type	67X-010	67X-020	67X-030	67X-040	
ATEX conform	Part no.	306700B	306700C	306700D	306700E	
<b>ATEX specification</b>		<b>C</b>	<b>C</b>	<b>A</b>	<b>A</b>	
Nominal power	W / HP	20 / 0.03	20 / 0.03	20 / 0.03	20 / 0.03	
Nominal speed	rpm	3000	2500	650	475	
Speed (idling)	rpm	6000	5000	1300	950	
Nominal torque	Nm / in.lbs	0.06 / 0.5	0.08 / 0.7	0.29 / 2.6	0.4 / 3.5	
Start torque min.	Nm / in.lbs	0.09 / 0.8	0.12 / 1	0.44 / 3.9	0.6 / 5.3	
Stall torque	Nm / in.lbs	0.12 / 1	0.15 / 1.33	0.55 / 4.87	0.75 / 6.64	
Air consumption	m <sup>3</sup> /min / cfm	0.1 / 3	0.1 / 3	0.1 / 3	0.1 / 3	
Weight	kg / lbs	0.16 / 0.3	0.16 / 0.3	0.16 / 0.3	0.16 / 0.3	
Hose I.D., supply air/exhaust air	mm / in.	3 / 1/8	3 / 1/8	3 / 1/8	3 / 1/8	

**Included in delivery:**

2 Slide connectors (M 5)

Performance data relate to an air pressure of 6 bar (85 PSI) and lubricated air. With oil-free operation the output will be reduced by 10 - 20%.

Motor size 0		right rotation				
Series 67X-	Type	67X-010R	67X-020R	67X-030R	67X-040R	
ATEX conform	Part no.	3067000B	3067000C	3067000D	3067000E	
<b>ATEX specification</b>		<b>C</b>	<b>C</b>	<b>A</b>	<b>A</b>	
Nominal power	W / HP	30/0.04	30/0.04	30/0.04	30/0.04	
Nominal speed	rpm	3000	2500	650	500	
Speed (idling)	rpm	6000	5000	1300	1000	
Nominal torque	Nm / in.lbs	0.1/0.885	0.11/0.97	0.44/3.89	0.57/5.04	
Start torque min.	Nm / in.lbs	0.12/1.06	0.17/1.5	0.66/5.84	0.86/7.61	
Stall torque	Nm / in.lbs	0.18/1.59	0.22/1.95	0.84/7.43	1.09/9.65	
Air consumption	m <sup>3</sup> /min / cfm	0.1/3.53	0.1/3.53	0.1/3.53	0.1/3.53	
Weight	kg / lbs	0.13/0.29	0.13/0.29	0.13/0.29	0.13/0.29	
Hose I.D., supply air/exhaust air	mm / in.	3 / 1/8	3 / 1/8	3 / 1/8	3 / 1/8	

**Included in delivery:**

1 Slide connector (M 5)

Performance data relate to an air pressure of 6 bar (85 PSI) and lubricated air. With oil-free operation the output will be reduced by 10 - 20%.

### Optional Equipment

for Motor size 0		reversible	right rotation
<b>Flange</b> incl. mounting screws	Part no.	4451872	4451872
1 Silencer (M 5)	Part no.	811355	-
<b>Maintenance unit with lubricator*</b>	Part no.	820454A	820454A
Connection thread		G 1/4	G 1/4
<b>Maintenance unit without lubricator*</b>	Part no.	822408A	822408A
Connection thread		G 1/4	G 1/4
<b>Replacement part set</b> consisting of: vanes, sealant rings, o-rings and silencers	Part no.	446083B	446083B

\*) Maintenance unit consists of pressure regulator valve, filter and optionally with or without lubricator

Please note that these motor gears are not stall-proof. If a higher application-based torque cannot be limited by the customer (e.g. by use of a slip clutch), please contact our application specialists to discuss an alternative solution.

Of course you can also purchase individual replacement parts from us. Please contact us if this is a requirement. Our standard maintenance units are not ATEX conform. Please contact us if this is a requirement

Allowable shaft loading see page 36.

Further notes for soundproofing see page 36/37.

**Motor size 0**  
**Series 67X-**  
 reversible, right rotation

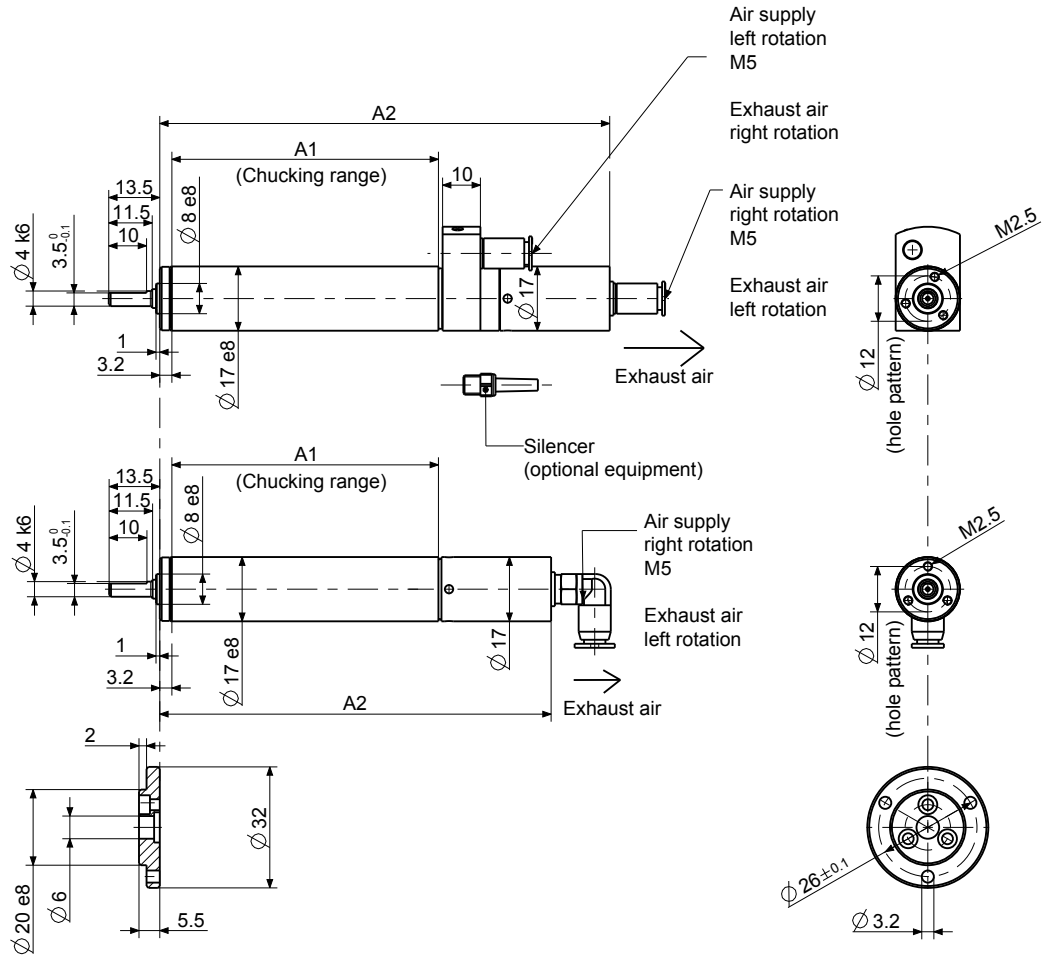
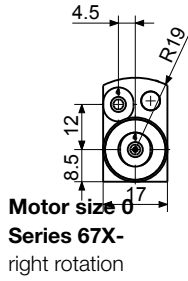

Dimensions in mm

p4400563

Motor size	Series 67X- Type		Dimensions of motor (mm)	
			A1	A2
0	67X-010	67X-020	64.5	112.9
	67X-030	67X-040	70.5	119
	67X-010R	67X-020R	64.5	97.4
	67X-030R	67X-040R	70.5	103.5

## 80/100 W ADVANCED LINE AIR MOTOR

Motor size 1		reversible								
Series 67X- ATEX conform	 Type Part no.	67X-001 306710A	67X-011 306710B	67X-021 306710C	67X-031 306710D	67X-061 306710H	67X-081 306710E	67X-331 306710G	67X-551 306710F	67X-581 306710I
ATEX specification		A	C	C	A	A	A	A	A	A
Nominal power	W/HP	80/0.11	80/0.11	80/0.11	80/0.11	80/0.11	80/0.11	80/0.11	80/0.11	80/0.11
Nominal speed	rpm	14500	3500	950	650	*)	*)	*)	*)	*)
Speed (idling)	rpm	29000	7000	1900	1300	490	240	60	30	8
Nominal torque	Nm/in.lbs	0.05/0.44	0.22/1.9	0.8/7	1.2/11	*)	*)	*)	*)	*)
Start torque min.	Nm/in.lbs	0.08/0.71	0.33/2.9	1.2/11	1.8/16	*)	*)	*)	*)	*)
Stall torque	Nm/in.lbs	0.10/0.89	0.41/3.63	1.5/13.28	*)	*)	*)	*)	*)	*)
Max. admissible torque	Nm/in.lbs	-	-	-	2/17.7	2/17.7	2/17.7	2/17.7	2/17.7	2/17.7
Air consumption	m <sup>3</sup> /min/cfm	0.23/8	0.23/8	0.23/8	0.23/8	0.23/8	0.23/8	0.23/8	0.23/8	0.23/8
Length L	mm/in.	96.5/3.76	96.5/3.76	105.5/4.1	105.5/4.1	113.5/4.4	113.5/4.4	122.5/4.78	122.5/4.78	130.5/5.09
Weight	kg/lbs	0.2/0.4	0.2/0.4	0.22/0.5	0.22/0.5	0.29/0.6	0.29/0.6	0.31/0.68	0.31/0.68	0.33/0.73
Hose I.D., supply air/exhaust air	mm/in.	4/5/32	4/5/32	4/5/32	4/5/32	4/5/32	4/5/32	4/5/32	4/5/32	4/5/32

Motor size 1		right rotation		
Series 67X- ATEX conform	 Type Part no.	67X-001R 3067100A	67X-011R 3067100B	67X-021R 3067100C
ATEX specification		A	C	C
Nominal power	W/HP	100/0.134	100/0.134	100/0.134
Nominal speed	rpm	15500	4300	1200
Speed (idling)	rpm	31000	8600	2400
Nominal torque	Nm/in.lbs	0.06/0.53	0.22/1.9	0.8/7
Start torque min.	Nm/in.lbs	0.09/0.8	0.33/2.9	1.2/11
Stall torque	Nm/in.lbs	0.11/0.97	0.41/3.63	1.5/13.28
Max. admissible torque	Nm/in.lbs	-	-	-
Air consumption	m <sup>3</sup> /min/cfm	0.23/8	0.23/8	0.23/8
Length L	mm/in.	96.5/3.76	96.5/3.76	105.5/4.1
Weight	kg/lbs	0.2/0.4	0.2/0.4	0.22/0.5
Hose I.D., supply air/exhaust air	mm/in.	4/5/32	4/5/32	4/5/32

### Included in delivery:

Slide connectors (M8 x 0.75)

Performance data relate to an air pressure of 6 bar (85 PSI) and lubricated air. With oil-free operation the output will be reduced by 10 - 20%.

\*) At the maximum permissible torque of the gear, operating speed is adjusted to the region of the idle speed.

This operating speed can be reduced to up to 25 % of the indicated idle speed by reducing pressure and additional exhaust air throttling.

For operation at very low speeds in relation to the idle speed, we recommend the use of spring-assisted vanes (Z vanes).

### Optional Equipment

	Part no.	for motor size 1
<b>Flange</b> incl. mounting screws	Part no.	4451812
<b>Bracket</b> incl. mounting screws	Part no.	4451802
<b>Silencer set</b>	Part no.	117968A
<b>Maintenance unit with lubricator*</b>	Part no.	820454A
Connection thread		G 1/4
<b>Maintenance unit without lubricator*</b>	Part no.	822408A
Connection thread		G 1/4
<b>Replacement part set</b> consisting of: vanes, sealant rings, o-rings and silencers	Part no.	446084B / for part no. 306710(0)A 446084C / for part no. 306710(0)B,C

\*) Maintenance unit consists of pressure regulator valve, filter and optionally with or without lubricator

Please note that these motor gears are not stall-proof. If a higher application-based torque cannot be limited by the customer (e.g. by use of a slip clutch), please contact our application specialists to discuss an alternative solution.

Of course you can also purchase individual replacement parts from us. Please contact us if this is a requirement.  
Our standard maintenance units are not ATEX conform. Please contact us if this is a requirement

Allowable shaft loading see page 36.

Further notes for soundproofing see page 36/37.

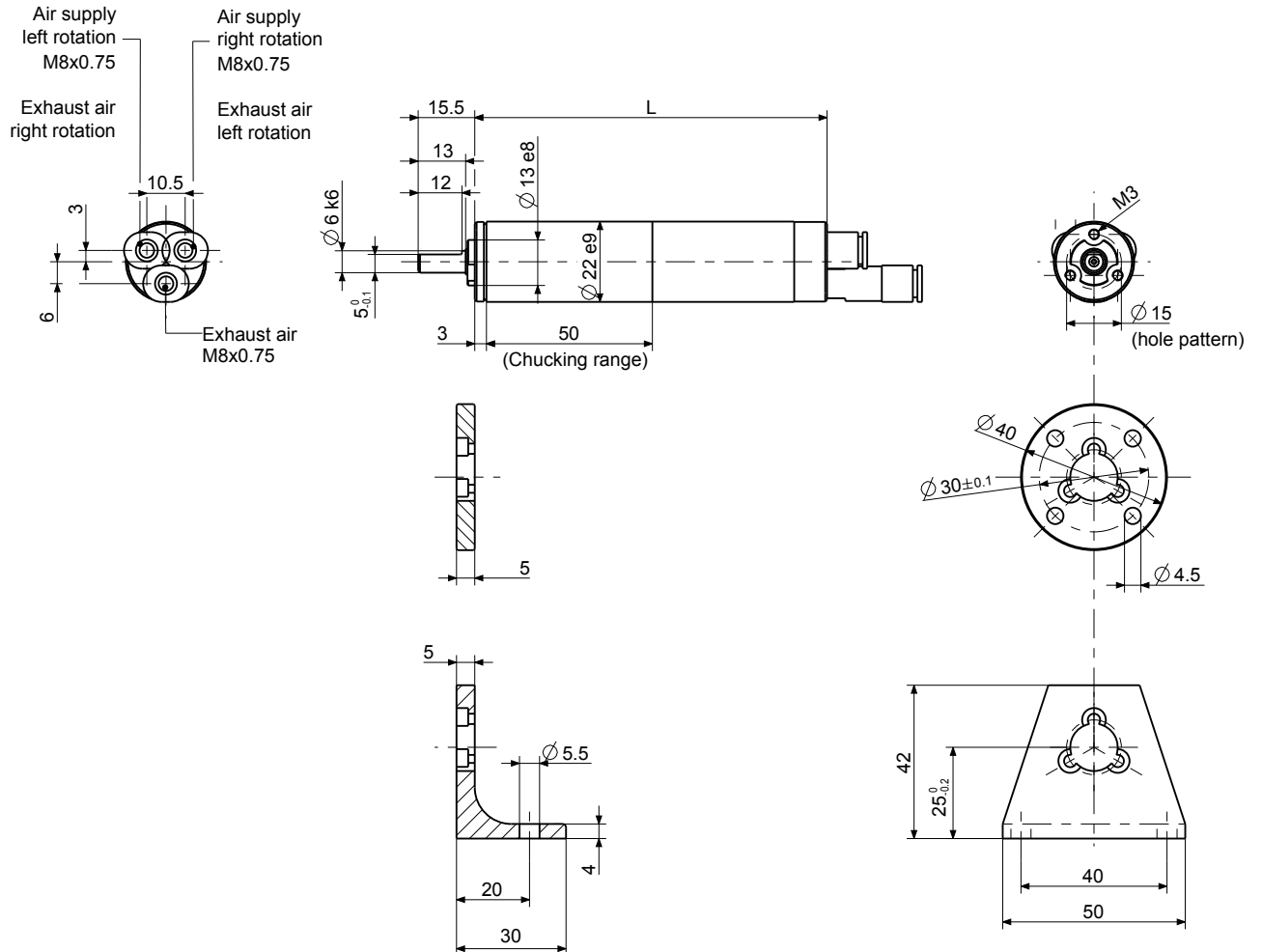

**Motor size 1**  
**Series 67X-**  
 reversible, right rotation



Dimensions in mm

p4400602

## 90/120/170 W ADVANCED LINE AIR MOTOR

Motor size 2		reversible						
<b>Series 67X-</b> ATEX conform	 <b>Type</b> Part no.	<b>67X-002</b> 306720A	<b>67X-012</b> 306720H	<b>67X-022</b> 306720B	<b>67X-032</b> 306720C	<b>67X-042</b> 306720D	<b>67X-052</b> 306720E	<b>67X-2521</b> 306720F
<b>ATEX specification</b>		<b>A</b>	<b>C</b>	<b>C</b>	<b>C</b>	<b>A</b>	<b>A</b>	<b>A</b>
<b>Series 67X-</b> with threaded shaft ATEX conform	 <b>Type</b> Part no.	<b>67X-002G</b> 3067207A	<b>67X-012G</b> 3067207H	<b>67X-022G</b> 3067207B	<b>67X-032G</b> 3067207C	<b>67X-042G</b> 3067207D	<b>67X-052G</b> 3067207E	<b>67X-2521G</b> 3067207F
<b>ATEX specification</b>		<b>A</b>	<b>C</b>	<b>C</b>	<b>C</b>	<b>A</b>	<b>A</b>	<b>A</b>
Nominal power	W / HP	120 / 0.16	120 / 0.16	120 / 0.16	120 / 0.16	120 / 0.16	120 / 0.16	90 / 0.12 <sup>1)</sup>
Nominal speed	rpm	11000	2750	1800	700	450	300	*)
Speed (idling)	rpm	22000	5500	3600	1400	900	600	100
Nominal torque	Nm / in.lbs	0.10 / 0.9	0.4 / 3.5	0.6 / 5.3	1.6 / 14	2.5 / 22	3.8 / 34	*)
Start torque min.	Nm / in.lbs	0.15 / 1.3	0.6 / 5.3	0.9 / 8	2.4 / 21	3.8 / 34	*)	*)
Stall torque	Nm / in.lbs	0.19 / 1.68	0.76 / 6.73	1.14 / 10.09	3 / 26.55	4.7 / 41.6	*)	*)
Max. admissible torque	Nm / in.lbs	-	-	-	-	-	5 / 44	5 / 44
Air consumption	m <sup>3</sup> /min / cfm	0.3 / 11	0.3 / 11	0.3 / 11	0.3 / 11	0.3 / 11	0.3 / 11	0.3 / 11
Weight	kg / lbs	0.35 / 0.8	0.35 / 0.8	0.35 / 0.8	0.4 / 0.9	0.4 / 0.9	0.4 / 0.9	0.45 / 1
Hose I.D., supply air/exhaust air	mm / in.	6 / ¼	6 / ¼	6 / ¼	6 / ¼	6 / ¼	6 / ¼	6 / ¼
Motor size 2		right rotation						
<b>Series 67X-</b> ATEX conform	 <b>Type</b> Part no.	<b>67X-002R</b> 3067200A	<b>67X-012R</b> 3067200H	<b>67X-022R</b> 3067200B	<b>67X-032R</b> 3067200C	<b>67X-042R</b> 3067200D	<b>67X-052R</b> 3067200E	
<b>ATEX specification</b>		<b>A</b>	<b>D</b>	<b>C</b>	<b>C</b>	<b>C</b>	<b>A</b>	
Nominal power	W / HP	170 / 0.23	170 / 0.23	170 / 0.23	170 / 0.23	170 / 0.23	170 / 0.23	
Nominal speed	rpm	12250	3075	2050	750	500	340	
Speed (idling)	rpm	24500	6150	4100	1500	1000	680	
Nominal torque	Nm / in.lbs	0.13 / 1.15	0.5 / 4.42	0.8 / 7.08	2.1 / 18.6	3.2 / 28.3	4.8 / 42.5	
Start torque min.	Nm / in.lbs	0.2 / 1.77	0.8 / 7.08	1.2 / 10.62	3.2 / 28.3	4.8 / 42.5	*)	
Stall torque	Nm / in.lbs	0.25 / 2.2	1 / 8.85	1.5 / 13.3	4.1 / 36.3	-	*)	
Max. admissible torque	Nm / in.lbs	-	-	-	-	5 / 44	5 / 44	
Air consumption	m <sup>3</sup> /min / cfm	0.3 / 11	0.3 / 11	0.3 / 11	0.3 / 11	0.3 / 11	0.3 / 11	
Weight	kg / lbs	0.35 / 0.8	0.35 / 0.8	0.35 / 0.8	0.4 / 0.9	0.4 / 0.9	0.4 / 0.9	
Hose I.D., supply air/exhaust air	mm / in.	6 / ¼	6 / ¼	6 / ¼	6 / ¼	6 / ¼	6 / ¼	

Performance data relate to an air pressure of 6 bar (85 PSI) and lubricated air. With oil-free operation the output will be reduced by 10 - 20%.

<sup>1)</sup> theoretical values for issuing the power diagram

\*) At the maximum permissible torque of the gear, operating speed is adjusted to the region of the idle speed.

This operating speed can be reduced to up to 25 % of the indicated idle speed by reducing pressure and additional exhaust air throttling.

For operation at very low speeds in relation to the idle speed, we recommend the use of spring-assisted vanes (Z vanes).

Optional Equipment	for motor size 2	
<b>Flange</b> incl. mounting screws	Part no.	4445694
<b>Bracket</b> incl. mounting screws	Part no.	4445722
<b>Silencer: motor operates in one direction</b> (right or left rotation)		
1 Hose nozzle	Part no.	823237
2 Silencer	Part no.	823236
<b>Silencer: motor is reversible</b> (right and left rotation)		
2 Hose nozzles	Part no.	823237
1 Silencer	Part no.	823236
<b>Maintenance unit with lubricator*</b>	Part no.	820454A
Connection thread		G 1/4
<b>Maintenance unit without lubricator*</b>	Part no.	822408A
Connection thread		G 1/4
<b>Replacement part set</b> consisting of: vanes, sealant rings, o-rings and silencers	Part no.	445580C / for part no. 306720(O)A 445580A / for part no. 306720(O)B-H

\*) Maintenance unit consists of pressure regulator valve, filter and optionally with or without lubricator

Please note that these motor gears are not stall-proof. If a higher application-based torque cannot be limited by the customer (e.g. by use of a slip clutch), please contact our application specialists to discuss an alternative solution.

Of course you can also purchase individual replacement parts from us. Please contact us if this is a requirement.  
Our standard maintenance units are not ATEX conform. Please contact us if this is a requirement

Allowable shaft loading see page 36.

Further notes for soundproofing see page 36/37.



**Motor size 2**  
**Series 67X-**  
 reversible and right rotation

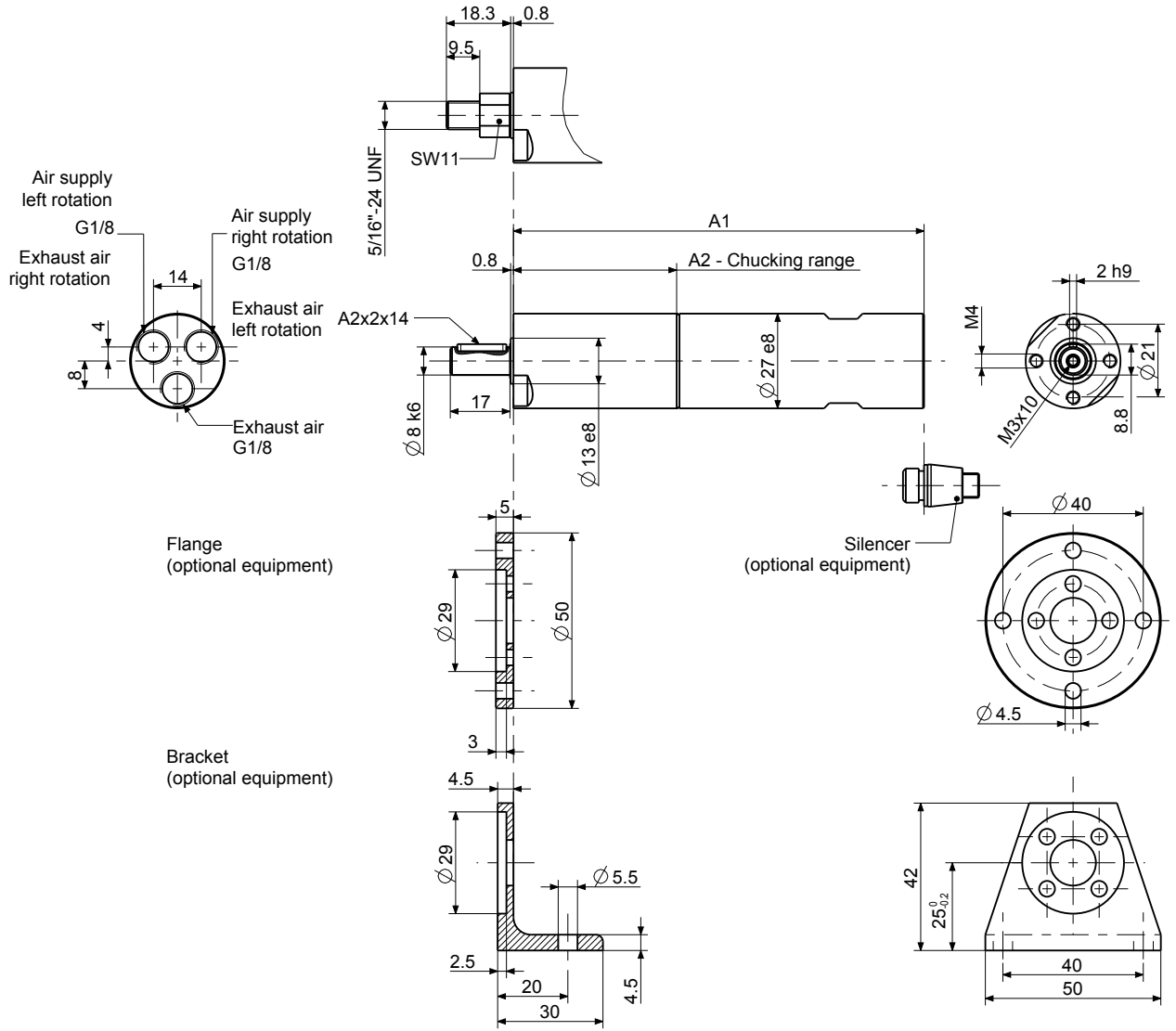

Dimensions in mm

p4402205

Motor size	Series 67X- Type			Dimensions of motor (mm)	
				A1	A2
2	67X-002(G,R)	67X-012(G,R)	67X-022(G,R)	117	46.5
	67X-032(G,R)	67X-042(G,R)	67X-052(G,R)	129.5	59
	67X-2521(G)			142	71.5

# 100/200/280 W ADVANCED LINE AIR MOTOR

Motor size 2.5		reversible							
<b>Series 67X-</b> ATEX conform 	Type	<b>67X-0025</b>	<b>67X-0125</b>	<b>67X-0225</b>	<b>67X-0725</b>	<b>67X-0325</b>	<b>67X-0425</b>	<b>67X-04251</b>	<b>67X-24251</b>
	Part no.	306725B	306725C	306725D	306725F	306725E	306725A	306725G	306725H
<b>ATEX specification</b>		<b>A</b>	<b>C</b>	<b>C</b>	<b>C</b>	<b>A</b>	<b>A</b>	<b>A</b>	<b>A</b>
<b>Series 67X- with threaded shaft</b> ATEX conform 	Type	<b>67X-0025G</b>	<b>67X-0125G</b>	<b>67X-0225G</b>	<b>67X-0725G</b>	<b>67X-0325G</b>	<b>67X-0425G</b>	<b>67X-04251G</b>	<b>67X-24251G</b>
	Part no.	3067257B	3067257C	3067257D	3067257F	3067257E	3067257A	3067257G	3067257H
<b>ATEX specification</b>		<b>A</b>	<b>C</b>	<b>C</b>	<b>C</b>	<b>A</b>	<b>A</b>	<b>A</b>	<b>A</b>
Nominal power	W / HP	200 / 0.27	200 / 0.27	200 / 0.27	200 / 0.27	200 / 0.27	200 / 0.27	100 / 0.13	200 / 0.27
Nominal speed	rpm	8000	2300	1200	700	350	180	90	*)
Speed (idling)	rpm	16000	4600	2400	1400	700	360	180	50
Nominal torque	Nm / in.lbs	0.24/2.12	0.8/7.08	1.6/14.16	2.7/23.9	5.4/47.8	10.6/93.81	10.5/92.9	*)
Start torque min.	Nm / in.lbs	0.35/3.1	1.2/10.62	2.4/21.24	4.1/36.3	8.2/72.6	15.9/140.7	15/132.75	*)
Stall torque	Nm / in.lbs	0.45/3.98	1.5/13.3	3/26.6	5.1/45.1	10.3/91.2	*)	*)	*)
Max. admissible torque	Nm / in.lbs	-	-	-	-	-	20/177	20/177	20/177
Air consumption	m <sup>3</sup> /min / cfm	0.37/13.06	0.37/13.06	0.37/13.06	0.37/13.06	0.37/13.06	0.37/13.06	0.27/9.53	0.37/13.06
Weight	kg / lbs	0.7/1.54	0.75/1.65	0.75/1.65	0.85/1.87	0.85/1.87	0.85/1.87	0.85/1.87	0.95/2.09
Hose I.D., supply air/exhaust air	mm /in.	10 / <sup>3</sup> / <sub>8</sub>	10 / <sup>3</sup> / <sub>8</sub>	10 / <sup>3</sup> / <sub>8</sub>	10 / <sup>3</sup> / <sub>8</sub>	10 / <sup>3</sup> / <sub>8</sub>	10 / <sup>3</sup> / <sub>8</sub>	10 / <sup>3</sup> / <sub>8</sub>	10 / <sup>3</sup> / <sub>8</sub>
Motor size 2.5		right rotation							
<b>Series 67X-</b> ATEX conform 	Type	<b>67X-0025R</b>	<b>67X-0125R</b>	<b>67X-0225R</b>	<b>67X-0725R</b>	<b>67X-0325R</b>	<b>67X-0425R</b>		
	Part no.	3067250B	3067250C	3067250D	3067250F	3067250E	3067250A		
<b>ATEX specification</b>		<b>A</b>	<b>C</b>	<b>C</b>	<b>C</b>	<b>A</b>	<b>A</b>		
Nominal power	W / HP	280 / 0.38	280 / 0.38	280 / 0.38	280 / 0.38	280 / 0.38	280 / 0.38		
Nominal speed	rpm	9000	2600	1350	750	395	200		
Speed (idling)	rpm	18000	5200	2700	1500	790	400		
Nominal torque	Nm / in.lbs	0.3 / 2.65	1.03 / 9.11	1.98 / 17.5	3.55 / 31.4	6.77 / 59.9	13.37/118.3		
Start torque min.	Nm / in.lbs	0.45 / 3.98	1.5 / 13.3	2.9 / 25.7	5.3 / 46.9	10.1 / 89.4	20 / 177		
Stall torque	Nm / in.lbs	0.55 / 4.9	1.95 / 17.3	3.7 / 32.7	6.7 / 59.3	12.8 / 113.3	*)		
Max. admissible torque	Nm / in.lbs	-	-	-	-	-	20/177		
Air consumption	m <sup>3</sup> /min / cfm	0.4/14.12	0.4/14.12	0.4/14.12	0.4/14.12	0.4/14.12	0.4/14.12		
Weight	kg / lbs	0.7/1.54	0.75/1.65	0.75/1.65	0.85/1.87	0.85/1.87	0.85/1.87		
Hose I.D., supply air/exhaust air	mm /in.	10 / <sup>3</sup> / <sub>8</sub>	10 / <sup>3</sup> / <sub>8</sub>	10 / <sup>3</sup> / <sub>8</sub>	10 / <sup>3</sup> / <sub>8</sub>	10 / <sup>3</sup> / <sub>8</sub>	10 / <sup>3</sup> / <sub>8</sub>		

Performance data relate to an air pressure of 6 bar (85 PSI) and lubricated air. With oil-free operation the output will be reduced by 10 - 20%.

\*) At the maximum permissible torque of the gear, operating speed is adjusted to the region of the idle speed.

This operating speed can be reduced to up to 25 % of the indicated idle speed by reducing pressure and additional exhaust air throttling.

For operation at very low speeds in relation to the idle speed, we recommend the use of spring-assisted vanes (Z vanes).

Optional Equipment	for motor size 2.5	
<b>Flange</b> incl. mounting screws	Part no.	4445305
<b>Bracket</b> incl. mounting screws	Part no.	4445393
<b>Silencer: motor operates in one direction (right or left rotation)</b>		
1 Hose nozzle	Part no.	823238 (1/8")
1 Silencer	Part no.	802675 (1/8")
1 Silencer	Part no.	802673 (1/4")
<b>Silencer: motor is reversible (right or left rotation)</b>		
2 Hose nozzles	Part no.	823238 (1/8")
1 Silencer	Part no.	802673 (1/4")
<b>Maintenance unit with lubricator*</b>	Part no.	820454A
Connection thread		G 1/4
<b>Maintenance unit without lubricator*</b>	Part no.	822408A
Connection thread		G 1/4
<b>Replacement part set</b>		
consisting of: vanes, sealant rings, o-rings and silencers	Part no.	444785A / for part no. 306725(0)A, C-H 444785E / for part no. 306725(0)B

\*) Maintenance unit consists of pressure regulator valve, filter and optionally with or without lubricator



Of course you can also purchase individual replacement parts from us. Please contact us if this is a requirement. Our standard maintenance units are not ATEX conform. Please contact us if this is a requirement



Allowable shaft loading see page 36.

Further notes for soundproofing see page 36/37.



# 130/300/400 W ADVANCED LINE AIR MOTOR

Motor size 3		reversible								
<b>Series 67X-</b> ATEX conform	 <b>Type</b> Part no.	<b>67X-003</b> 306730A	<b>67X-013</b> 306730B	<b>67X-023</b> 306730C	<b>67X-073</b> 306730D	<b>67X-083</b> 306730E	<b>67X-093</b> 306730F	<b>67X-0931</b> 306730G	<b>67X-1931</b> 306730K	<b>67X-2931</b> 306730H
<b>ATEX specification</b>		<b>A</b>	<b>D</b>	<b>C</b>	<b>C</b>	<b>A</b>	<b>A</b>	<b>A</b>	<b>A</b>	<b>A</b>
<b>Series 67X-</b> with threaded shaft ATEX conform	 <b>Type</b> Part no.	<b>67X-003G</b> 3067307A	<b>67X-013G</b> 3067307B	<b>67X-023G</b> 3067307C	<b>67X-073G</b> 3067307D	<b>67X-083G</b> 3067307E	<b>67X-093G</b> 3067307F	<b>67X-0931G</b> 3067307G	<b>67X-1931G</b> 3067307K	<b>67X-2931G</b> 3067307H
<b>ATEX specification</b>		<b>A</b>	<b>D</b>	<b>C</b>	<b>C</b>	<b>A</b>	<b>A</b>	<b>A</b>	<b>A</b>	<b>A</b>
Nominal power	W / HP	300 / 0.4	300 / 0.4	300 / 0.4	300 / 0.4	300 / 0.4	300 / 0.4	130 / 0.17	300 / 0.4	300 / 0.4
Nominal speed	rpm	7250	2300	1200	615	350	180	90	*)	*)
Speed (idling)	rpm	14500	4600	2400	1230	700	360	180	100	50
Nominal torque	Nm / in.lbs	0.4/3.54	1.2/10.62	2.4/21.24	4.65/41.15	8.15/72.13	15.9/140.7	13.8/122.13	*)	*)
Start torque min.	Nm / in.lbs	0.6/5.31	1.9/16.8	3.6/31.9	6.95/61.5	12.25/108.4	23.8/210.6	21/185.85	*)	*)
Stall torque	Nm / in.lbs	0.76/6.7	2.2/19.5	4.5/39.8	8.8/77.88	15.5/137.2	30.2/267.3	26.2/231.9	*)	*)
Max. admissible torque	Nm / in.lbs	-	-	-	-	-	-	-	36/318.6	36/318.6
Air consumption	m <sup>3</sup> /min / cfm	0.47/16.6	0.47/16.6	0.47/16.6	0.47/16.6	0.47/16.6	0.47/16.6	0.28/9.88	0.47/16.6	0.47/16.6
Weight	kg / lbs	1.0/2.2	1.05/2.31	1.05/2.31	1.10/2.42	1.15/2.53	1.15/2.53	1.15/2.53	1.25/2.75	1.25/2.75
Hose I.D., supply air/exhaust air	mm / in.	10 / <sup>3</sup> / <sub>8</sub>	10 / <sup>3</sup> / <sub>8</sub>	10 / <sup>3</sup> / <sub>8</sub>	10 / <sup>3</sup> / <sub>8</sub>	10 / <sup>3</sup> / <sub>8</sub>	10 / <sup>3</sup> / <sub>8</sub>	10 / <sup>3</sup> / <sub>8</sub>	10 / <sup>3</sup> / <sub>8</sub>	10 / <sup>3</sup> / <sub>8</sub>

Motor size 3		right rotation					
<b>Series 67X-</b> ATEX conform	 <b>Type</b> Part no.	<b>67X-003R</b> 3067300A	<b>67X-013R</b> 3067300B	<b>67X-023R</b> 3067300C	<b>67X-073R</b> 3067300D	<b>67X-083R</b> 3067300E	<b>67X-093R</b> 3067300F
<b>ATEX specification</b>		<b>A</b>	<b>D</b>	<b>C</b>	<b>C</b>	<b>A</b>	<b>A</b>
<b>Series 67X-</b> with threaded shaft ATEX conform	 <b>Type</b> Part no.	<b>67X-003GR</b> 30673014A	<b>67X-013GR</b> 30673014B	<b>67X-023GR</b> 30673014C	<b>67X-073GR</b> 30673014D	<b>67X-083GR</b> 30673014E	<b>67X-093GR</b> 30673014F
<b>ATEX specification</b>		<b>A</b>	<b>D</b>	<b>C</b>	<b>C</b>	<b>A</b>	<b>A</b>
Nominal power	W / HP	400/0.54	400/0.54	400/0.54	400/0.54	400/0.54	400/0.54
Nominal speed	rpm	8800	2550	1300	745	425	220
Speed (idling)	rpm	17600	5100	2600	1490	850	440
Nominal torque	Nm / in.lbs	0.43/3.8	1.5/13.3	2.9/18.6	5.1/45.1	9/79.65	17.4/154
Start torque min.	Nm / in.lbs	0.65/5.75	2.2/19.5	4.4/38.9	7.65/67.7	13.4/118.6	26/230.1
Stall torque	Nm / in.lbs	0.82/7.3	2.8/24.8	5.5/48.7	9.7/85.8	17/150.45	33/292.05
Max. admissible torque	Nm / in.lbs	-	-	-	-	-	-
Air consumption	m <sup>3</sup> /min / cfm	0.5/17.65	0.5/17.65	0.5/17.65	0.5/17.65	0.5/17.65	0.5/17.65
Weight	kg / lbs	1.0/2.2	1.05/2.31	1.05/2.31	1.10/2.42	1.15/2.53	1.15/2.53
Hose I.D., supply air/exhaust air	mm / in.	10 / <sup>3</sup> / <sub>8</sub>	10 / <sup>3</sup> / <sub>8</sub>	10 / <sup>3</sup> / <sub>8</sub>	10 / <sup>3</sup> / <sub>8</sub>	10 / <sup>3</sup> / <sub>8</sub>	10 / <sup>3</sup> / <sub>8</sub>

Performance data relate to an air pressure of 6 bar (85 PSI) and lubricated air. With oil-free operation the output will be reduced by 10 - 20%.

\*) At the maximum permissible torque of the gear, operating speed is adjusted to the region of the idle speed.

This operating speed can be reduced to up to 25 % of the indicated idle speed by reducing pressure and additional exhaust air throttling.

For operation at very low speeds in relation to the idle speed, we recommend the use of spring-assisted vanes (Z vanes).

Optional Equipment	for motor size 3	
<b>Flange</b> incl. mounting screws	Part no.	4446105
<b>Bracket</b> incl. mounting screws	Part no.	4446112
<b>Silencer: motor operates in one direction</b> (right or left rotation)		
1 Hose nozzle	Part no.	410541 (1/4")
1 Silencer	Part no.	802673 (1/4")
1 Silencer	Part no.	802673 (1/4")
<b>Silencer: motor is reversible</b> (right or left rotation)		
2 Hose nozzles	Part no.	410541 (1/4")
1 Silencer	Part no.	802673 (1/4")
<b>Maintenance unit with lubricator*</b>	Part no.	820455A
Connection thread		G 1/2
<b>Maintenance unit without lubricator*</b>	Part no.	822409A
Connection thread		G 1/2
<b>Replacement part set</b> consisting of: vanes, sealant rings, o-rings and silencers	Part no.	444786A / for part no. 306730(0)B-K 444786L / for part no. 306730(0)A

\*) Maintenance unit consists of pressure regulator valve, filter and optionally with or without lubricator



Of course you can also purchase individual replacement parts from us. Please contact us if this is a requirement.  
Our standard maintenance units are not ATEX conform. Please contact us if this is a requirement

Allowable shaft loading see page 36.

Further notes for soundproofing see page 36/37.



## 300/400 W ADVANCED LINE AIR MOTOR with high torque

Motor size 3 with high torque		reversible				
Series 67- ATEX conform	 Type Part no.	67X-613 306730I	67X-623 306730L	67X-673 306730M	67X-413 306730N	67X-423 306730O
ATEX specification		A	A	A	A	A
Nominal power	W / HP	300 / 0.4	300 / 0.4	300 / 0.4	300 / 0.4	300 / 0.4
Nominal speed	rpm	85	45	25	13	7
Speed (idling)	rpm	170	90	50	26	14
Nominal torque	Nm / in.lbs	33.7 / 298.2	63.6 / 562.9	114.5 / 1013.3	220 / 1947	410 / 3628.5
Start torque min.	Nm / in.lbs	50.5 / 446.9	95.4 / 844.3	171.5 / 1517.8	330 / 2920.5	*)
Stall torque	Nm / in.lbs	64 / 566.4	120.9 / 1070	217 / 1920.45	418 / 3699.3	*)
Max. admissible torque	Nm / in.lbs	-	-	-	-	600 / 5310
Air consumption	m <sup>3</sup> /min / cfm	0.47 / 16.6	0.47 / 16.6	0.47 / 16.6	0.47 / 16.6	0.47 / 16.6
Weight	kg / lbs	2.7 / 5.94	2.6 / 5.72	2.9 / 6.38	3.5 / 7.7	3.5 / 7.7
Hose I.D., supply air/exhaust air	mm / in.	10 / 3/8	10 / 3/8	10 / 3/8	10 / 3/8	10 / 3/8
Motor size 3 with high torque		right rotation				
Series 67- ATEX conform	 Type Part no.	67X-613R 3067300I	67X-623R 3067300L	67X-673R 3067300M	67X-413R 3067300N	67X-423R 3067300O
ATEX specification		A	A	A	A	A
Nominal power	W / HP	400/0.54	400/0.54	400/0.54	400/0.54	400/0.54
Nominal speed	rpm	105	55	31	15	8
Speed (idling)	rpm	210	110	62	30	16
Nominal torque	Nm / in.lbs	36.3/321.25	69.4/614.2	123.2/1090	254/2248	477/4221.45
Start torque min.	Nm / in.lbs	54.5/482.3	104/920.4	184.4/1631.94	382/3380.7	*)
Stall torque	Nm / in.lbs	69/610.65	132/1168.2	234/2070.9	483.8/4281.63	*)
Max. admissible torque	Nm / in.lbs	-	-	-	-	600/5310
Air consumption	m <sup>3</sup> /min / cfm	0.5/17.65	0.5/17.65	0.5/17.65	0.5/17.65	0.5/17.65
Weight	kg / lbs	2.7 / 5.94	2.6 / 5.72	2.9 / 6.38	3.5 / 7.7	3.5 / 7.7
Hose I.D., supply air/exhaust air	mm / in.	10 / 3/8	10 / 3/8	10 / 3/8	10 / 3/8	10 / 3/8

Performance data relate to an air pressure of 6 bar (85 PSI) and lubricated air. With oil-free operation the output will be reduced by 10 - 20%.

\*) At the maximum permissible torque of the gear, operating speed is adjusted to the region of the idle speed.

This operating speed can be reduced to up to 25 % of the indicated idle speed by reducing pressure and additional exhaust air throttling.

For operation at very low speeds in relation to the idle speed, we recommend the use of spring-assisted vanes (Z vanes).

Optional Equipment	for motor size 3	
<b>Flange</b> incl. mounting screws	Part no.	4134632
<b>Bracket</b> incl. mounting screws	Part no.	44461738
<b>Silencer: motor operates in one direction (right or left rotation)</b>		
1 Hose nozzle	Part no.	410541 (1/4")
2 Silencer	Part no.	802673 (1/4")
<b>Silencer: motor is reversible (right or left rotation)</b>		
2 Hose nozzles	Part no.	410541 (1/4")
1 Silencer	Part no.	802673 (1/4")
<b>Maintenance unit with lubricator*</b>	Part no.	820455A
Connection thread		G 1/2
<b>Maintenance unit without lubricator*</b>	Part no.	822409A
Connection thread		G 1/2
<b>Replacement part set</b> consisting of: vanes, sealant rings, o-rings and silencers	Part no.	444786O for part no. 306730(O)I,L,M 444786C for part no. 306730(O)N,O

\*) Maintenance unit consists of pressure regulator valve, filter and optionally with or without lubricator

Of course you can also purchase individual replacement parts from us. Our standard maintenance units are not ATEX conform. Please contact us if this is a requirement.

Allowable shaft loading see page 36.

Further notes for soundproofing see page 36/37.

Notes to the pressure regulator valve for our ATEX conform brake motors, please find on page 38.

**Motor size 3 High torque stainless steel motors**

**Series 67(X)-**

reversible  
right rotation

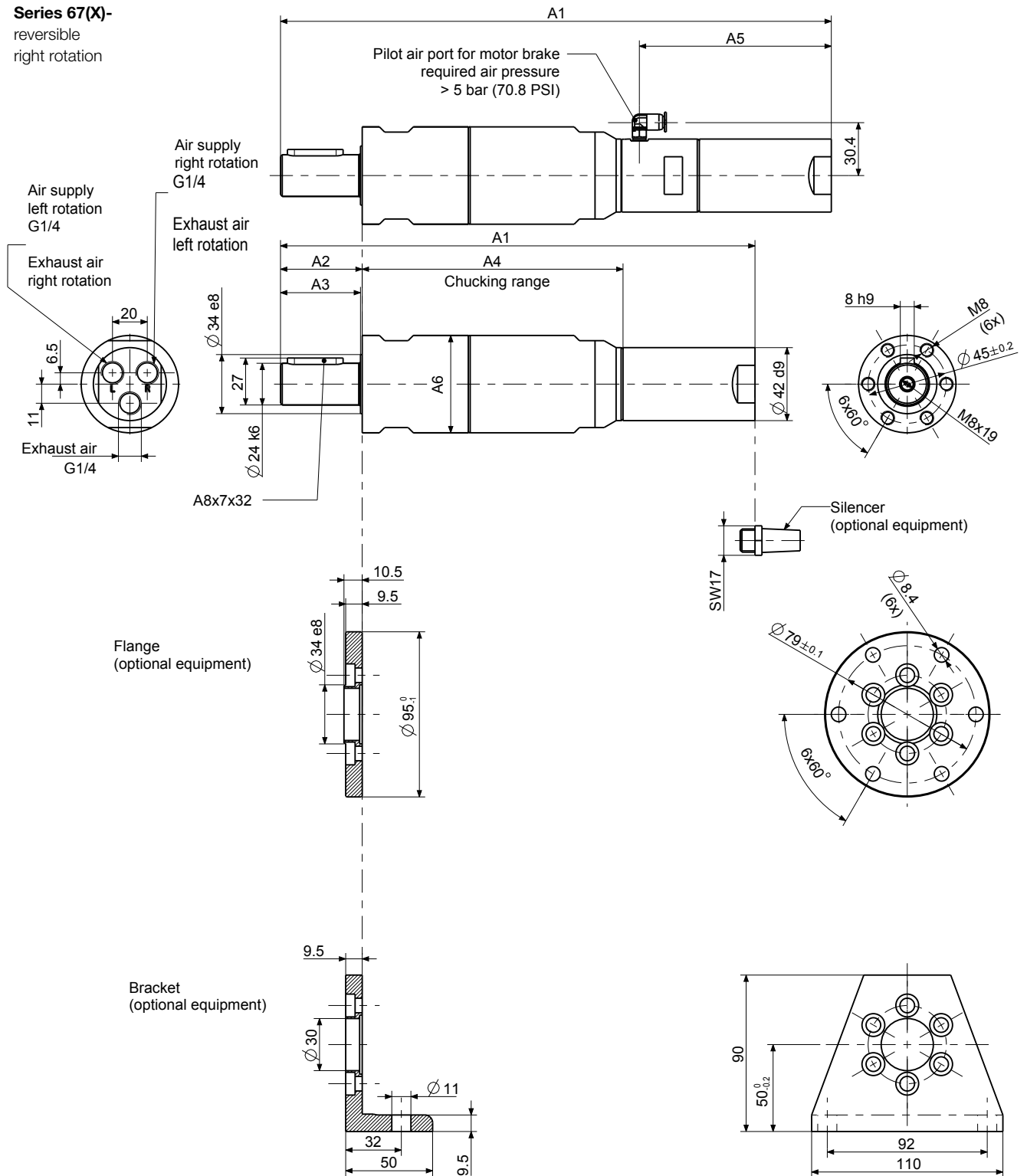

Dimensions in mm

p444204

Motor size	Series 67(X)- Type		Dimensions of motor (mm)				
			A1	A2	A3	A4	A5
3	67X-613(R)	67X-623(R)	257.1	44	43	134.1	
	67X-673(R)		272.9			149.9	-
	67X-413(R)	67X-423(R)	279.2	47	46	156.2	

## 300 W ADVANCED LINE AIR MOTOR with integrated holding brake

Motor size 3 with holding brake		reversible				
<b>Series 67-</b> ATEX conform	 <b>Type</b> Part no.	<b>67X-613B</b> 1030291P	<b>67X-623B</b> 1030291R	<b>67X-673B</b> 1030291S	<b>67X-413B</b> 1030291N	<b>67X-423B</b> 1030291O
<b>ATEX specification</b>		<b>A</b>	<b>A</b>	<b>A</b>	<b>A</b>	<b>A</b>
<b>Series 67-</b> without ATEX authorization	<b>Type</b> Part no.	<b>67-613B-1</b> 103029P	<b>67-623B-1</b> 103029R	<b>67-673B-1</b> 103029S	<b>67-413B-1</b> 103029N	<b>67-423B-1</b> 103029O
Nominal power	W / HP	300 / 0.4	300 / 0.4	300 / 0.4	300 / 0.4	300 / 0.4
Nominal speed	rpm	85	45	25	13	7
Speed (idling)	rpm	170	90	50	26	14
Nominal torque	Nm / in.lbs	33.7 / 298.2	63.6 / 562.9	114.5 / 1013.3	220 / 1947	410 / 3628.5
Start torque min.	Nm / in.lbs	50.5 / 446.9	95.4 / 844.29	171.5 / 1517.8	330 / 2920.5	-
Stall torque	Nm / in.lbs	64 / 566.4	120.9 / 1070	217 / 1920.45	418 / 3699.3	-
Max. admissible torque	Nm / in.lbs	-	-	-	-	600 / 5310
Brake torque	Nm / in.lbs	82 / 725.7	160 / 1416	282 / 2495.7	554 / 4902.9	-
Air consumption	m <sup>3</sup> /min / cfm	0.47 / 16.6	0.47 / 16.6	0.47 / 16.6	0.47 / 16.6	0.47 / 16.6
Weight	kg / lbs	3.1 / 6.82	3 / 6.6	3.3 / 7.26	3.9 / 8.58	3.9 / 8.58
Hose I.D., supply air/exhaust air	mm / in.	10 / <sup>3</sup> / <sub>8</sub>	10 / <sup>3</sup> / <sub>8</sub>	10 / <sup>3</sup> / <sub>8</sub>	10 / <sup>3</sup> / <sub>8</sub>	10 / <sup>3</sup> / <sub>8</sub>

Performance data relate to an air pressure of 6 bar (85 PSI) and lubricated air. With oil-free operation the output will be reduced by 10 - 20%.

Optional Equipment	for motor size 3	
<b>Flange</b> incl. mounting screws	Part no.	4134632
<b>Bracket</b> incl. mounting screws	Part no.	44461738
<b>Silencer: motor operates in one direction (right or left rotation)</b>		
1 Hose nozzle	Part no.	410541 (1/4")
2 Silencer	Part no.	802673 (1/4")
<b>Silencer: motor is reversible (right or left rotation)</b>		
2 Hose nozzles	Part no.	410541 (1/4")
1 Silencer	Part no.	802673 (1/4")
<b>Maintenance unit with lubricator*</b>	Part no.	820455A
Connection thread		G 1/2
<b>Maintenance unit without lubricator*</b>	Part no.	822409A
Connection thread		G 1/2
<b>Replacement part set</b> consisting of: vanes, sealant rings, o-rings and silencers	Part no.	444786O for part no. 103029(1)P,R,S 444786C for part no. 103029(1)N,O
<b>Replacement part set for brake</b> consisting of: discs, pressure spring and o-rings	Part no.	446096C

\* Maintenance unit consists of pressure regulator valve, filter and optionally with or without lubricator

Of course you can also purchase individual replacement parts from us. Our standard maintenance units are not ATEX conform. Please contact us if this is a requirement.

Allowable shaft loading see page 36.

Further notes for soundproofing see page 36/37.

Notes to the pressure regulator valve for our ATEX conform brake motors, please find on page 38.



**Motor size 3 High torque stainless steel motors**

**Series 67(X)-**

reversible

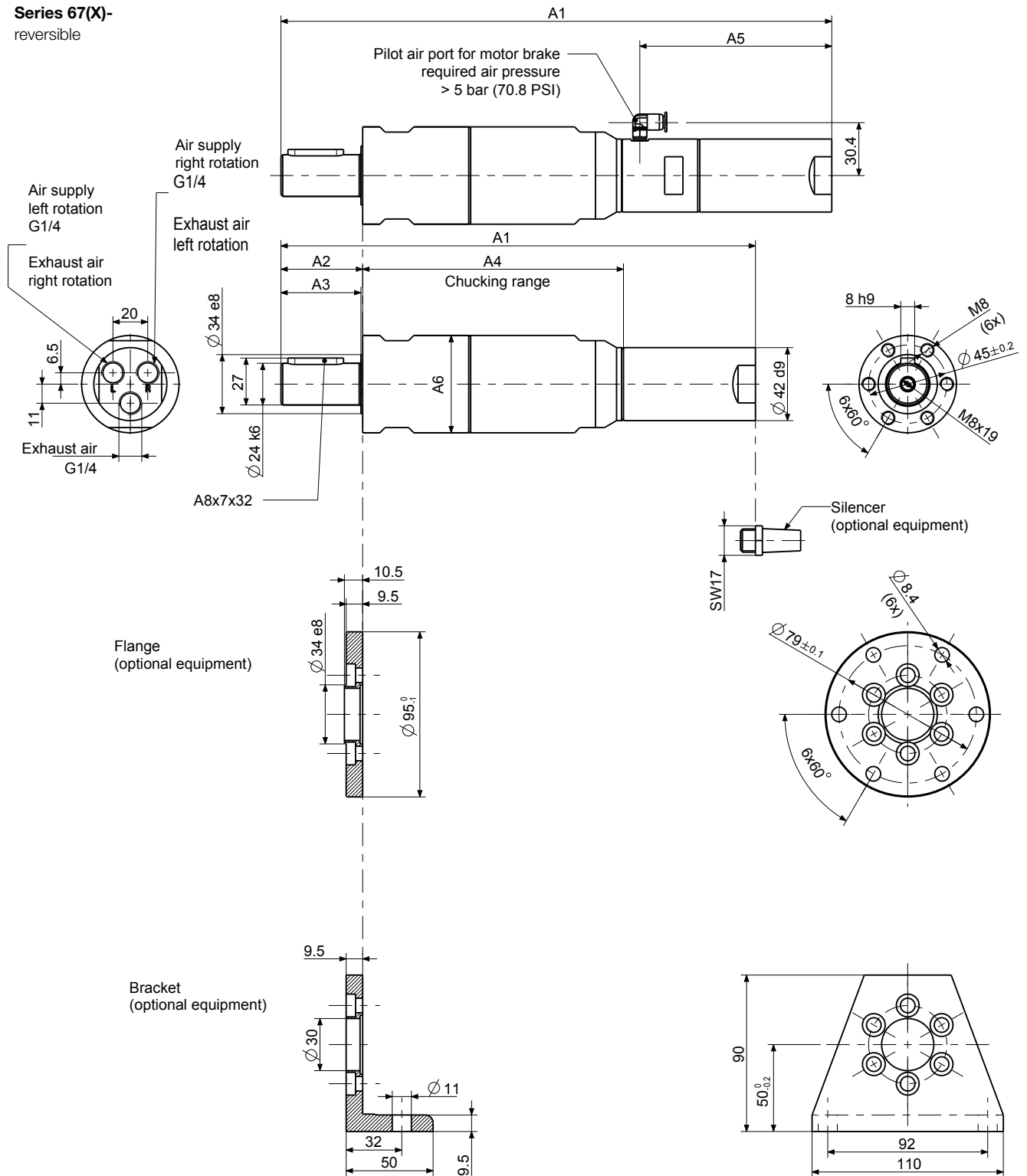



Dimensions in mm

p444204

Motor size	Series 67(X)-		Dimensions of motor (mm)				
	Type	Type	A1	A2	A3	A4	A5
3	67(X)-613B(-1)	67(X)-623B(-1)	300.1	44	43	134.1	110.4
	67(X)-673B(-1)		316.8			149.9	
	67(X)-413B(-1)	67(X)-423B(-1)	316.8	47	46	156.2	

# 100/130/200/300 W ADVANCED LINE AIR MOTOR with integrated holding brake

Motor size 2.5 with holding brake		reversible								
<b>Series 67-</b> ATEX conform 	<b>Type</b>	<b>67X-0025B</b>	<b>67X-0125B</b>	<b>67X-0225B</b>	<b>67X-0725B</b>	<b>67X-0325B</b>	<b>67X-0425B</b>	<b>67X-04251B</b>	<b>67X-24251B</b>	
	Part no.	1073991B	1073991C	1073991D	1073991F	1073991E	1073991A	1073991G	1073991H	
<b>ATEX specification</b>		<b>A</b>	<b>C</b>	<b>C</b>	<b>C</b>	<b>A</b>	<b>A</b>	<b>A</b>	<b>A</b>	
<b>Series 67-</b> without ATEX authorization	<b>Type</b>	<b>67-0025B-1</b>	<b>67-0125B-1</b>	<b>67-0225B-1</b>	<b>67-0725B-1</b>	<b>67-0325B-1</b>	<b>67-0425B-1</b>	<b>67-04251B-1</b>	<b>67-24251B-1</b>	
	Part no.	107399B	107399C	107399D	107399F	107399E	107399A	107399G	107399H	
Nominal power	W/HP	200/0.27	200/0.27	200/0.27	200/0.27	200/0.27	200/0.27	100/0.134	200/0.27	
Nominal speed	rpm	8000	2300	1200	700	350	180	90	-	
Speed (idling)	rpm	16000	4600	2400	1400	700	360	180	50	
Nominal torque	Nm/in.lbs	0.24/2.12	0.8/7.08	1.6/14.16	2.7/23.9	5.4/47.8	10.6/93.8	10.5/92.9	-	
Start torque min.	Nm/in.lbs	0.35/3.1	1.2/10.6	2.4/21.2	4.1/36.3	8.2/72.6	15.9/140.7	15/132.75	-	
Stall torque	Nm/in.lbs	0.45/3.98	1.5/13.275	3/26.55	5.1/45.135	10.3/91.155	-	-	-	
Max. admissible torque	Nm/in.lbs	-	-	-	-	20/177	20/177	20/177	20/177	
Brake torque	Nm/in.lbs	1/8.85	3.4/30.1	6.7/59.3	11.8/104.43	-	-	-	-	
Air consumption	m <sup>3</sup> /min/cfm	0.37/13.06	0.37/13.06	0.37/13.06	0.37/13.06	0.37/13.06	0.37/13.06	0.27/9.53	0.37/13.06	
Weight	kg/lbs	1/2.2	1.05/2.31	1.05/2.31	1.15/2.53	1.15/2.53	1.15/2.53	1.36/3	1.36/3	
Hose I.D., supply air/exhaust air	mm/in.	10 / 3/8	10 / 3/8	10 / 3/8	10 / 3/8	10 / 3/8	10 / 3/8	10 / 3/8	10 / 3/8	
Motor size 3 with holding brake		reversible								
<b>Series 67-</b> ATEX conform 	<b>Type</b>	<b>67X-003B</b>	<b>67X-013B</b>	<b>67X-023B</b>	<b>67X-073B</b>	<b>67X-083B</b>	<b>67X-093B</b>	<b>67X-0931B</b>	<b>67X-1931B</b>	<b>67X-2931B</b>
	Part no.	1030291A	1030291B	1030291C	1030291D	1030291E	1030291F	1030291G	1030291K	1030291H
<b>ATEX specification</b>		<b>A</b>	<b>D</b>	<b>C</b>	<b>C</b>	<b>A</b>	<b>A</b>	<b>A</b>	<b>A</b>	<b>A</b>
<b>Series 67-</b> without ATEX authorization	<b>Type</b>	<b>67-003B-1</b>	<b>67-013B-1</b>	<b>67-023B-1</b>	<b>67-073B-1</b>	<b>67-083B-1</b>	<b>67-093B-1</b>	<b>67-0931B-1</b>	<b>67-1931B-1</b>	<b>67-2931B-1</b>
	Part no.	103029A	103029B	103029C	103029D	103029E	103029F	103029G	103029K	103029H
Nominal power	W/HP	300/0.4	300/0.4	300/0.4	300/0.4	300/0.4	300/0.4	130/0.174	300/0.4	300/0.4
Nominal speed	rpm	7250	2300	1200	615	350	180	90	-	-
Speed (idling)	rpm	14500	4600	2400	1230	700	360	180	100	50
Nominal torque	Nm/in.lbs	0.4/3.54	1.2/10.6	2.4/21.2	4.65/41.15	8.15/72.13	15.9/140.7	13.8/122.13	-	-
Start torque min.	Nm/in.lbs	0.6/5.3	1.9/16.8	3.6/31.86	6.95/61.5	12.25/108.4	23.9/211.5	21/185.85	-	-
Stall torque	Nm/in.lbs	0.76/6.73	2.2/19.5	4.5/39.8	8.8/77.88	15.2/134.52	30.2/267.27	26.2/231.87	-	-
Max. admissible torque	Nm/in.lbs	-	-	-	-	-	36/318.6	36/318.6	36/318.6	36/318.6
Brake torque	Nm/in.lbs	1/8.85	3.4/30.1	6.7/59.3	11.8/104.43	20.6/182.31	-	-	-	-
Air consumption	m <sup>3</sup> /min/cfm	0.47/16.6	0.47/16.6	0.47/16.6	0.47/16.6	0.47/16.6	0.47/16.6	0.28/9.88	0.47/16.6	0.47/16.6
Weight	kg/lbs	1.35/2.97	1.4/3.08	1.4/3.08	1.45/3.19	1.5/3.3	1.5/3.3	1.7/3.74	1.8/1.76	1.8/1.76
Hose I.D., supply air/exhaust air	mm/in.	10 / 3/8	10 / 3/8	10 / 3/8	10 / 3/8	10 / 3/8	10 / 3/8	10 / 3/8	10 / 3/8	10 / 3/8

Performance data relate to an air pressure of 6 bar (85 PSI) and lubricated air. With oil-free operation the output will be reduced by 10 - 20%.

Optional Equipment:	for motor size 2.5	for motor size 3
<b>Flange</b> incl. mounting screws	Part no. 4445305	4446105
<b>Bracket</b> incl. mounting screws	Part no. 4445393	4446112
<b>Silencer: motor operates in one direction (right or left rotation)</b>		
1 Hose nozzle	Part no. 823238 (1/8")	410541 (1/4")
1 Silencer	Part no. 802675 (1/8")	802673 (1/4")
1 Silencer	Part no. 802673 (1/4")	802673 (1/4")
<b>Silencer: Motor is reversible (right or left rotation)</b>		
2 Hose nozzles	Part no. 823238 (1/8")	410541 (1/4")
1 Silencer	Part no. 802673 (1/4")	802673 (1/4")
<b>Maintenance unit with lubricator*</b>	Part no. 820454A	820455A
Connection thread	G 1/4	G 1/2
<b>Maintenance unit without lubricator*</b>	Part no. 822408A	822409A
Connection thread	G 1/4	G 1/2
<b>Replacement part set</b> consisting of: vanes, sealant rings, o-rings and silencers	Part no. 444785A for part no. 107399(1)A,C-H 444785E for part no. 107399(1)B	444786A for part no. 103029(1)B-H,K 444786L for part no. 103029(1)A
<b>Replacement part set for brake</b> consisting of: discs, pressure spring and o-rings	Part no. 446096C	446096C

\*) Maintenance unit consists of pressure regulator valve, filter and optionally with or without lubricator

Of course you can also purchase individual replacement parts from us. Our standard maintenance units are not ATEX conform. Please contact us if this is a requirement.



Allowable shaft loading see page 36.

Further notes for soundproofing see page 36/37.

Notes to the pressure regulator valve for our ATEX conform brake motors, please find on page 38.



# 300/600/850 W ADVANCED LINE AIR MOTOR ATEX conform/without ATEX authorization for drill-chuck

Motor size 6		reversible									
<b>Series 67X-</b> ATEX conform		<b>Type</b> Part no.	<b>67X-006</b> 306760A	<b>67X-086</b> 306760N	<b>67X-016</b> 306760H	<b>67X-026</b> 306760B	<b>67X-036</b> 306760C	<b>67X-046</b> 306760D	<b>67X-056</b> 306760E	<b>67X-066</b> 306760F	<b>67X-0661</b> 306760G
<b>ATEX specification</b>			<b>A</b>	<b>A</b>	<b>D</b>	<b>C</b>	<b>C</b>	<b>A</b>	<b>A</b>	<b>A</b>	<b>A</b>
<b>Series 67X-</b> with threaded shaft ATEX conform		<b>Type</b> Part no.	-	-	<b>67X-016G</b> 1141327H	<b>67X-026G</b> 1141327B	<b>67X-036G</b> 1141327C	<b>67X-046G</b> 1141327D	-	-	-
<b>ATEX specification</b>			-	-	<b>D</b>	<b>C</b>	<b>C</b>	<b>A</b>	-	-	-
<b>Series 67-</b> without ATEX authorization for drill-chuck		<b>Type</b> Part no.	-	-	<b>67-016B16</b> 114132H	<b>67-026B16</b> 114132B	<b>67-036B16</b> 114132C	<b>67-046B16</b> 114132D	<b>67-056B16</b> 114132E	<b>67-066B16</b> 114132F	<b>67-0661B16</b> 114132G
Nominal power	W / HP		600/0.8	600/0.8	600/0.8	600/0.8	600/0.8	600/0.8	600/0.8	600/0.8	300/0.4
Nominal speed	rpm		6750	2750	2000	1500	1000	350	250	170	90
Speed (idling)	rpm		13500	5500	4000	3000	2000	700	500	340	180
Nominal torque	Nm / in.lbs		0.85/7.5	2/17.7	2.8/24.78	3.8/33.63	5.7/50.44	16.3/144.3	22.9/202.7	33.7/298.25	31.8/281.43
Start torque min.	Nm / in.lbs		1.25/11.06	3.1/27.435	4.3/38.055	5.7/50.445	8.5/75.225	24.5/216.825	34.3/303.55	50.6/447.81	47.7/422.15
Stall torque	Nm / in.lbs		1.6/14.16	3.9/34.5	5.4/47.8	7.2/63.72	10.8/95.58	31.1/275.24	43.5/385	64/566.4	60.4/534.54
Air consumption	m <sup>3</sup> /min / cfm		0.85/30	0.85/30	0.85/30	0.85/30	0.85/30	0.85/30	0.85/30	0.85/30	0.55/19.4
Weight	kg / lbs		2.2/4.84	2.7/5.94	2.3/5.06	2.3/5.06	2.3/5.06	2.6/5.72	2.7/5.94	2.7/5.94	2.7/5.94
Hose I.D., supply air/exhaust air	mm / in.		12 / 1/2	12 / 1/2	12 / 1/2	12 / 1/2	12 / 1/2	12 / 1/2	12 / 1/2	12 / 1/2	12 / 1/2
Motor size 6		right rotation									
<b>Series 67X-</b> ATEX conform		<b>Type</b> Part no.	<b>67X-006R</b> 3067600A	<b>67X-086R</b> 3067600N	<b>67X-016R</b> 3067600H	<b>67X-026R</b> 3067600B	<b>67X-036R</b> 3067600C	<b>67X-046R</b> 3067600D	<b>67X-056R</b> 3067600E	<b>67X-066R</b> 3067600F	
<b>ATEX specification</b>			<b>A</b>	<b>A</b>	<b>D</b>	<b>C</b>	<b>C</b>	<b>A</b>	<b>A</b>	<b>A</b>	
Nominal power	W / HP		850	850/1.14	850/1.14	850/1.14	850/1.14	850/1.14	850/1.14	850/1.14	
Nominal speed	rpm		7250	2985	2100	1650	1075	375	275	180	
Speed (idling)	rpm		14500	5970	4200	3300	2150	750	550	360	
Nominal torque	Nm / in.lbs		1.12/9.9	2.7/23.9	3.9/34.5	4.9/43.4	7.6/67.3	21.6/191.2	29.5/261.1	45.1/399.1	
Start torque min.	Nm / in.lbs		1.68/14.9	4.1/36.3	5.8/51.3	7.4/65.5	11.3/100	32.5/287.6	44.3/392.1	67.6/598.3	
Stall torque	Nm / in.lbs		2.13/18.85	5.2/46.02	7.3/64.6	9.3/82.3	14.3/126.5	41.1/363.7	56.1/496.5	85.7/758.4	
Air consumption	m <sup>3</sup> /min / cfm		0.85/30	0.85/30	0.85/30	0.85/30	0.85/30	0.85/30	0.85/30	0.85/30	
Weight	kg / lbs		2.2/4.84	2.7/5.94	2.3/5.1	2.3/5.1	2.3/5.1	2.6/5.72	2.7/5.94	2.7/5.94	
Hose I.D., supply air/exhaust air	mm / in.		12 / 1/2	12 / 1/2	12 / 1/2	12 / 1/2	12 / 1/2	12 / 1/2	12 / 1/2	12 / 1/2	

Performance data relate to an air pressure of 6 bar (85 PSI) and lubricated air. With oil-free operation the output will be reduced by 10 - 20%.

Optional Equipment:	for motor size 6	
<b>Flange</b> incl. mounting screws	Part no.	4446166
<b>Bracket</b> incl. mounting screws	Part no.	4446176
<b>Silencer: motor operates in one direction (right or left rotation)</b>		
1 Hose nozzle	Part no.	410540 (3/8")
1 Silencer	Part no.	802671 (3/8")
1 Silencer	Part no.	802666 (1/2")
<b>Silencer: Motor is reversible (right or left rotation)</b>		
2 Hose nozzles	Part no.	410540 (3/8")
1 Silencer	Part no.	802666 (1/2")
<b>Drill-Chuck</b>		
Range 1 - 13 mm / B 16	Part no.	804652
<b>Quick change chuck</b>		
Range 1 - 13 mm / B 16	Part no.	804663
<b>Maintenance unit with lubricator*</b>		
Connection thread	Part no.	820455A G 1/2
<b>Maintenance unit without lubricator*</b>		
Connection thread	Part no.	822409A G 1/2
<b>Replacement part set</b> consisting of:		
Part no.	444787A for part no. 306760B-D,H/for part no. 3067600B-D,H/for part no. 114132B-D, H	
Part no.	444787B for part no. 306760E-G/for part no. 3067600E-F/for part no. 114132E-G	
	444787H for part no. 306760A,N/for part no. 3067600A,N	

\*) Maintenance unit consists of pressure regulator valve, filter and optionally with or without lubricator

\*\*\*) the output will be reduced by approx. 10%

Of course you can also purchase individual replacement parts from us. Please contact us if this is a requirement. Our standard maintenance units are not ATEX conform. Please contact us if this is a requirement

Allowable shaft loading see page 36.

Further notes for soundproofing see page 36/37.

**Motor size 6, Series 67(X)-, reversible and right rotation**

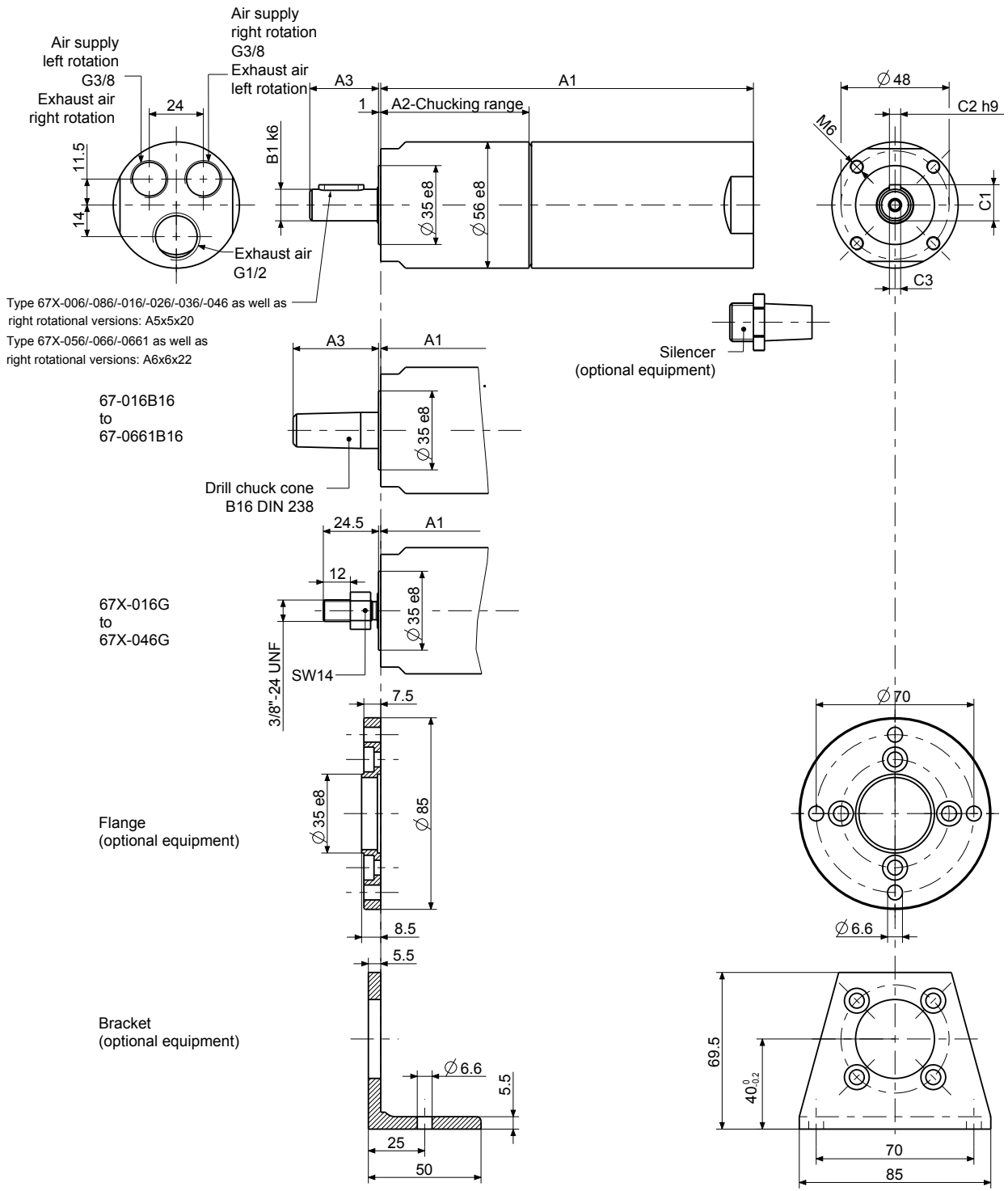

Type 67X-006/-086/-016/-026/-036/-046 as well as right rotational versions: A5x5x20  
 Type 67X-056/-066/-0661 as well as right rotational versions: A6x6x22

67-016B16 to 67-0661B16

67X-016G to 67X-046G

Flange (optional equipment)

Bracket (optional equipment)

Silencer (optional equipment)

Dimensions in mm

p4402988

Motor size	Series 67(X)- Type				Dimensions of motor (mm)						
	A1	A2	A3	B1	C1	C2	C3				
6	67X-006	67X-016(G)	67X-026(G)	67X-036(G)	165.5	66	30.5	14	16	5	M5x12
	67X-046(G)	67X-086			183.5	84					
	67X-056	67X-066	67X-0661		180	80.5	35	19	21.5	6	M6x12
	67X-006R	67X-016R	67X-026R	67X-036R	165.5	66	30.5	14	16	5	M5x12
	67X-046R	67X-086R			183.5	84					
	67X-056R	67X-066R			180	80.5	35	19	21.5	6	M6x12
	67-016B16	67-026B16	67-036B16		166	66	37.5	-	-	-	-
	67-046B16				184	84					
	67-056B16	67-066B16	67-0661B16		180	80.5	38				

## 900/1100 W ADVANCED LINE AIR MOTOR ATEX conform

Motor size 7		reversible							
Series 67X- ATEX conform	 Type Part no.	67X-007 306770A	67X-087 306770N	67X-017 306770H	67X-027 306770B	67X-037 306770C	67X-047 306770D	67X-057 306770E	67X-067 306770F
ATEX specification		A	A	D	C	C	A	A	A
Nominal power	W / HP	900/1.2	900/1.2	900/1.2	900/1.2	900/1.2	900/1.2	900/1.2	900/1.2
Nominal speed	rpm	6300	2600	1835	1425	950	325	235	155
Speed (idling)	rpm	12600	5200	3670	2850	1900	650	470	310
Nominal torque	Nm / in.lbs	1.35/11.95	3.3/29.2	4.6/40.7	6/53.1	9/79.65	26.4/233.6	36.5/323	55.4/490.3
Start torque min.	Nm / in.lbs	2/17.7	4.9/43.36	7/61.95	9/79.65	13.5/119.5	39.6/350.46	54.8/485	83.1/735.4
Stall torque	Nm / in.lbs	2.6/23	6.2/54.87	8.9/78.8	11.4/100.89	17.1/151.3	50.2/444.27	69.4/614.19	105.3/931.9
Air consumption	m <sup>3</sup> /min / cfm	1.4/49.42	1.4/49.42	1.4/49.42	1.4/49.42	1.4/49.42	1.4/49.42	1.4/49.42	1.4/49.42
Weight	kg / lbs	2.5/5.5	2.9/6.38	2.6/5.72	2.6/5.72	2.6/5.72	2.9/6.38	3/6.6	3/6.6
Hose I.D., supply air/exhaust air	mm / in.	12 / 1/2	12 / 1/2	12 / 1/2	12 / 1/2	12 / 1/2	12 / 1/2	12 / 1/2	12 / 1/2

Motor size 7		right rotation							
Series 67X- ATEX conform	 Type Part no.	67X-007R 3067700A	67X-087R 3067700N	67X-017R 3067700H	67X-027R 3067700B	67X-037R 3067700C	67X-047R 3067700D	67X-057R 3067700E	67X-067R 3067700F
ATEX specification		A	A	D	C	C	A	A	A
Nominal power	W / HP	1100	1100	1100	1100	1100	1100	1100	1100
Nominal speed	rpm	6550	2625	1900	1460	970	330	240	155
Speed (idling)	rpm	13100	5250	3800	2920	1940	660	480	310
Nominal torque	Nm / in.lbs	1.6/14.2	4/35.4	5.5/48.7	7.2/63.7	10.8/95.6	31.8/281.4	43.8/387.6	101.6/899.2
Start torque min.	Nm / in.lbs	2.4/21.2	6/53.1	8.3/73.5	10.8/95.6	16.2/143.4	47.7/422.1	65.7/581.4	128.8/1139.9
Stall torque	Nm / in.lbs	3.0/26.55	7.6/67.3	10.5/92.9	13.7/121.2	20.5/181.4	60.5/535.4	83.2/736.3	105.3/931.9
Air consumption	m <sup>3</sup> /min / cfm	1.4/49.42	1.4/49.42	1.4/49.42	1.4/49.42	1.4/49.42	1.4/49.42	1.4/49.42	1.4/49.42
Weight	kg / lbs	2.5/5.5	2.9/6.38	2.6/5.72	2.6/5.72	2.6/5.72	2.9/6.38	3/6.6	3/6.6
Hose I.D., supply air/exhaust air	mm / in.	12 / 1/2	12 / 1/2	12 / 1/2	12 / 1/2	12 / 1/2	12 / 1/2	12 / 1/2	12 / 1/2

Performance data relate to an air pressure of 6 bar (85 PSI) and lubricated air. With oil-free operation the output will be reduced by 10 - 20%.

Optional Equipment:		for motor size 7	
<b>Flange</b> incl. mounting screws	Part no.	4446166	
<b>Bracket</b> incl. mounting screws	Part no.	4446176	
<b>Silencer: motor operates in one direction (right or left rotation)</b>			
1 Hose nozzle	Part no.	410540 (3/8")	
1 Silencer	Part no.	802671 (3/8") **)	
1 Silencer	Part no.	802666 (1/2") **)	
<b>Silencer: Motor is reversible (right or left rotation)</b>			
2 Hose nozzles	Part no.	410540 (3/8")	
1 Silencer	Part no.	802666 (1/2")	
<b>Drill-Chuck</b>			
Range 1 - 13 mm / B 16	Part no.	-	
<b>Quick change chuck</b>			
Range 1 - 13 mm / B 16	Part no.	-	
<b>Maintenance unit with lubricator*</b>	Part no.	821608A G 3/4	
<b>Maintenance unit without lubricator*</b>	Part no.	826982A G 3/4	
<b>Replacement part set</b> consisting of: vanes, sealant rings, o-rings and silencers	Part no.	444919A / for part no. 306770B-D, H and 3067700B-D, H 444919B / for part no. 306770E-F and 3067700E-F 444919F / for part no. 306770A, N and 3067700A, N	

\*) Maintenance unit consists of pressure regulator valve, filter and optionally with or without lubricator

\*\* the output will be reduced by approx. 10%

Of course you can also purchase individual replacement parts from us. Please contact us if this is a requirement. Our standard maintenance units are not ATEX conform. Please contact us if this is a requirement

Allowable shaft loading see page 36.

Further notes for soundproofing see page 36/37.

**Motor size 7, Series 67(X)-**, reversible and right rotation

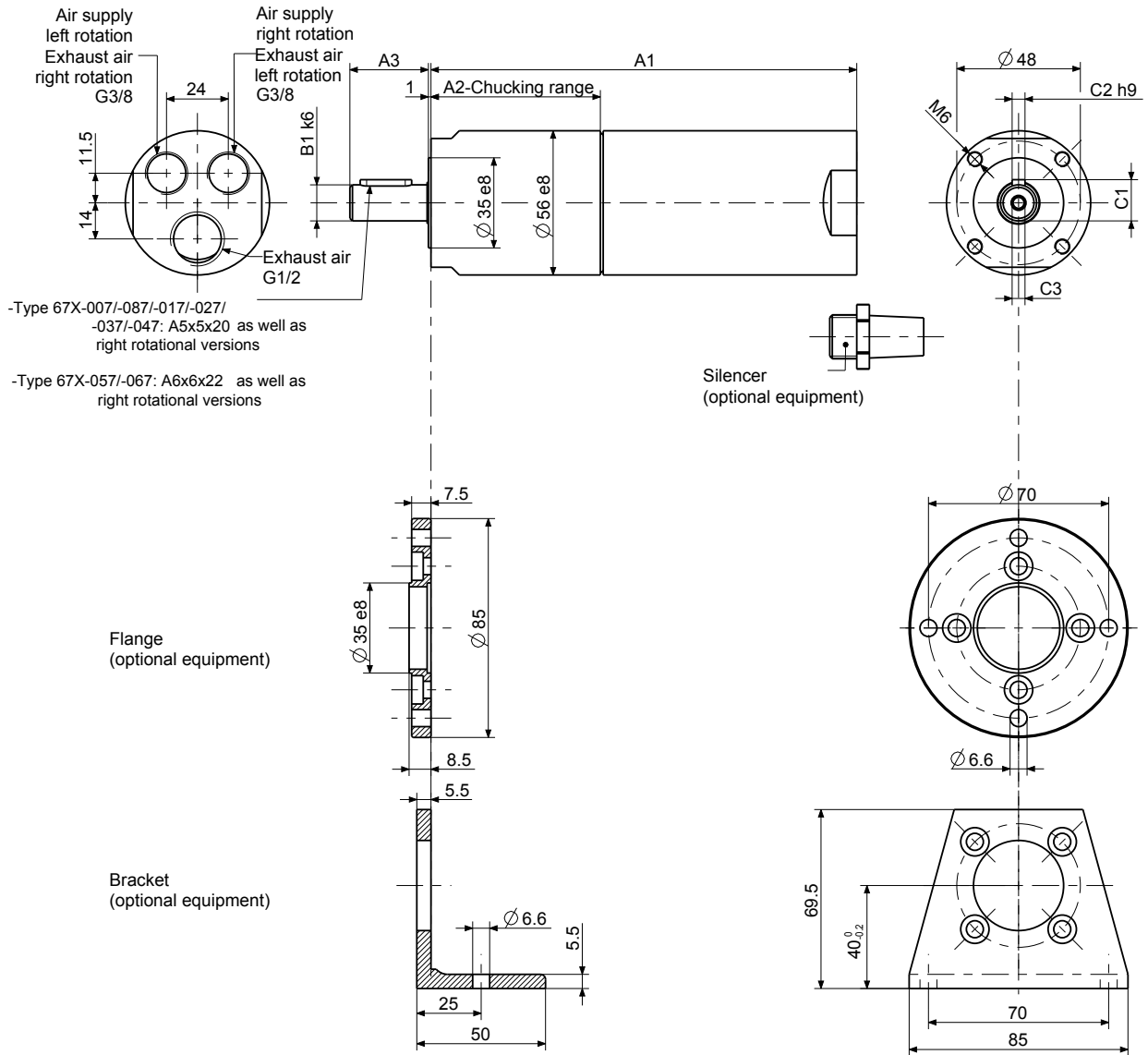

Dimensions in mm

p4402988

Motor size	Series 67(X)- Type				Dimensions of motor (mm)						
	A1	A2	A3	B1	C1	C2	C3				
7	67X-007(R)	67X-017(R)	67X-027(R)	67X-037(R)	190.5	66	30.5	14	16	5	M5x12
	67X-047(R)	67X-087(R)			208.5	84					
	67X-057(R)	67X-067(R)			205	81	35	19	21.5	6	M6x12

## 600/850 W ADVANCED LINE AIR MOTOR with high torque

Motor size 6 with high torque		reversible			
Series 67X- ATEX conform	Type Part no.	67X-746 306760I	67X-756 306760K	67X-766 306760L	67X-516 306760M
<b>ATEX specification</b>		<b>A</b>			
Nominal power	W / HP	600/0.8	600/0.8	600/0.8	600/0.8
Nominal speed	rpm	85	65	42	24
Speed (idling)	rpm	170	130	84	48
Nominal torque	Nm / in.lbs	67.4/596.5	88.1/779.7	136.4/1207.14	238.7/2112.5
Start torque min.	Nm / in.lbs	101.1/894.7	132.2/1170	204.6/1810.7	358.1/3169.2
Stall torque	Nm / in.lbs	128/1132.8	167.4/1481.49	259.2/2293.9	453.5/4013.5
Air consumption	m <sup>3</sup> /min / cfm	0.85/30	0.85/30	0.85/30	0.85/30
Weight	kg / lbs	3.6/7.92	3.6/7.92	3.6/7.92	4.4/9.68
Hose I.D., supply air/exhaust air	mm / in.	12 / 1/2	12 / 1/2	12 / 1/2	12 / 1/2
Motor size 6 with high torque		right rotation			
Series 67X- ATEX conform	Type Part no.	67X-746R 3067600I	67X-756R 3067600K	67X-766R 3067600L	67X-516R 3067600M
<b>ATEX specification</b>		<b>A</b>			
Nominal power	W / HP	850/1.14	850/1.14	850/1.14	850/1.14
Nominal speed	rpm	95	67	45	25
Speed (idling)	rpm	190	134	90	50
Nominal torque	Nm / in.lbs	85/752.25	120/1062	180/1593	325/2876.25
Start torque min.	Nm / in.lbs	128/1133	180/1593	270/2389.5	487/4310
Stall torque	Nm / in.lbs	162/1433.7	228.5/2022.2	-	-
Max. admissible torque	Nm / in.lbs	-	-	300/2655	600/5310
Air consumption	m <sup>3</sup> /min / cfm	0.85/30	0.85/30	0.85/30	0.85/30
Weight	kg / lbs	3.6/7.92	3.6/7.92	3.6/7.92	4.4/9.68
Hose I.D., supply air/exhaust air	mm / in.	12 / 1/2	12 / 1/2	12 / 1/2	12 / 1/2

Performance data relate to an air pressure of 6 bar (85 PSI) and lubricated air. With oil-free operation the output will be reduced by 10 - 20%.

Optional Equipment	for motor size 6	
<b>Flange</b> incl. mounting screws	Part no.	4134632
<b>Bracket</b> incl. mounting screws	Part no.	44461738
<b>Silencer: motor operates in one direction (right or left rotation)</b>		
1 Hose nozzle	Part no.	410540 (3/8")
1 Silencer	Part no.	802671 (3/8") **
1 Silencer	Part no.	802666 (1/2") **
<b>Silencer: Motor is reversible (right or left rotation)</b>		
2 Hose nozzles	Part no.	410540 (3/8")
1 Silencer	Part no.	802666 (1/2")
<b>Maintenance unit with lubricator*</b>	Part no.	820455A
Connection thread		G 1/2
<b>Maintenance unit without lubricator*</b>	Part no.	822409A
Connection thread		G 1/2
<b>Replacement part set</b> consisting of: vanes, sealant rings, o-rings and silencers	Part no.	444787L for types 67X-746(R) to 67X-766(R) 444787E for type 67X-516(R)

\*) Maintenance unit consists of pressure regulator valve, filter and optionally with or without lubricator

\*\* ) the output will be reduced by approx. 10%

Of course you can also purchase individual replacement parts from us. Please contact us if this is a requirement. Our standard maintenance units are not ATEX conform. Please contact us if this is a requirement

Allowable shaft loading see page 36.

Further notes for soundproofing see page 36/37.



**Motor size 6 High torque stainless steel motors**

**Series 67X-**

reversible and right rotation

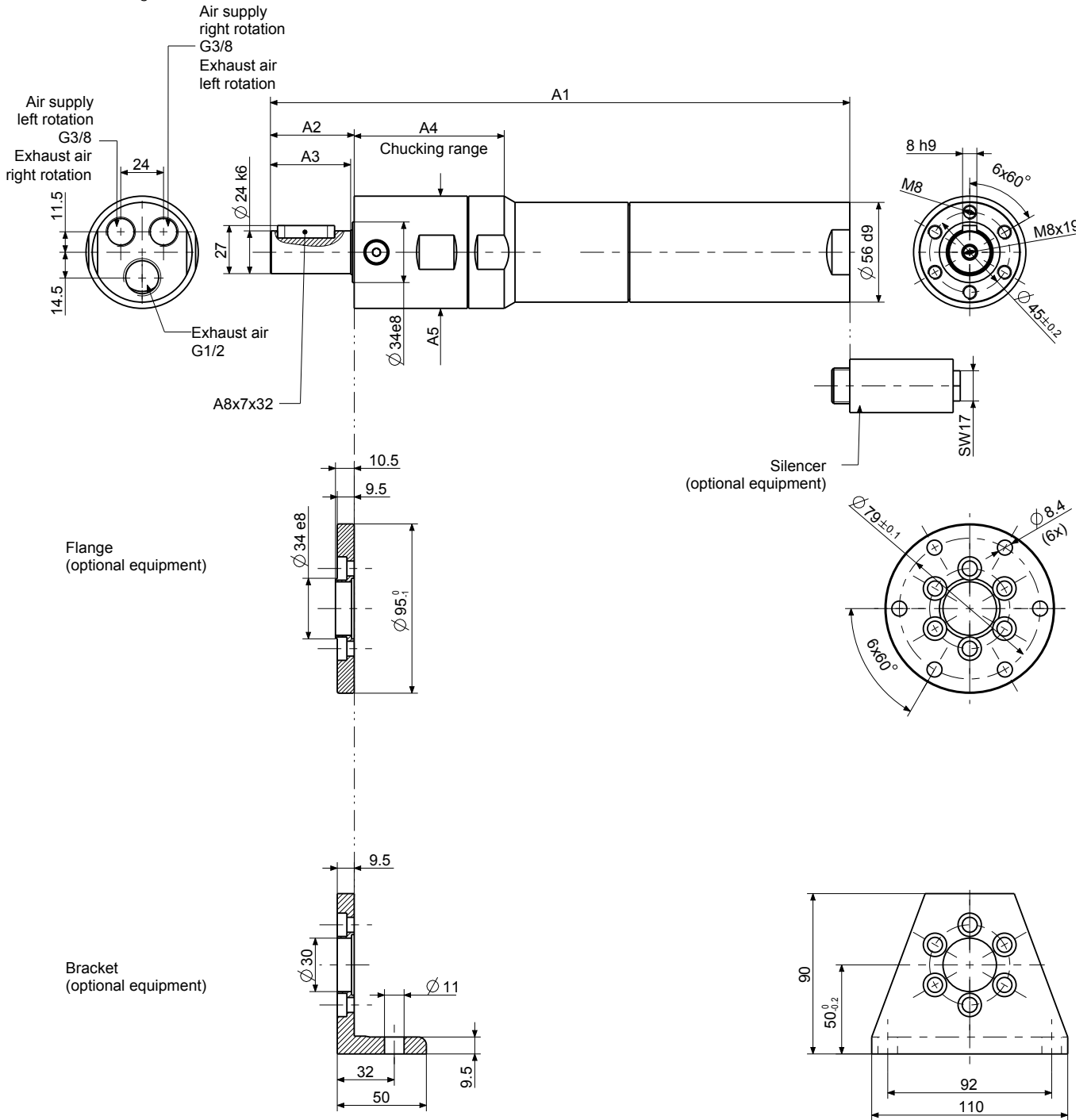

Dimensions in mm

p444338

Motor size	Series 67X-			Dimensions of motor (mm)				
	Type			A1	A2	A3	A4	A5
6	67X-746(R)	67X-756(R)	67X-766(R)	286.4	47	45	61	56e8
	67X-516(R)			300	47	45	84.2	63h8

## 900/1100 W ADVANCED LINE AIR MOTOR with high torque

Motor size 7 with high torque		reversible			
Series 67X- ATEX conform	Type Part no.	67X-747 306770I	67X-757 306770K	67X-767 306770L	67X-517 306770M
<b>ATEX specification</b>		<b>A</b>			
Nominal power	W / HP	900/1.2	900/1.2	900/1.2	900/1.2
Nominal speed	rpm	80	60	40	22
Speed (idling)	rpm	160	120	80	44
Nominal torque	Nm / in.lbs	107.4/950.5	143.2/1267.32	214.8/1901	390.6/3456.81
Start torque min.	Nm / in.lbs	161.1/1425.7	214.8/1901	-	585.9/5185.2
Stall torque	Nm / in.lbs	204.1/1806.3	272.1/2408.1	-	-
Max. admissible torque	Nm / in.lbs	-	-	300/2655	600/5310
Air consumption	m <sup>3</sup> /min / cfm	1.4/49.42	1.4/49.42	1.4/49.42	1.4/49.42
Weight	kg / lbs	3.8/8.36	3.9/8.58	3.9/8.58	4.7/10.34
Hose I.D., supply air/exhaust air	mm / in.	12 / 1/2	12 / 1/2	12 / 1/2	12 / 1/2
Motor size 7 with high torque		right rotation			
Series 67X- ATEX conform	Type Part no.	67X-747R 3067700I	67X-757R 3067700K	67X-767R 3067700L	67X-517R 3067700M
<b>ATEX specification</b>		<b>A</b>			
Nominal power	W / HP	1100/1.5	1100/1.5	1100/1.5	1100/1.5
Nominal speed	rpm	80	60	40	22
Speed (idling)	rpm	160	120	80	44
Nominal torque	Nm / in.lbs	131/1159.35	175/1548.75	262.6/2324	477/4221.45
Start torque min.	Nm / in.lbs	197/1743.45	262.6/2324	-	-
Stall torque	Nm / in.lbs	249.5/2208	-	-	-
Max. admissible torque	Nm / in.lbs	-	300/2655	300/2655	600/5310
Air consumption	m <sup>3</sup> /min / cfm	1.4/49.42	1.4/49.42	1.4/49.42	1.4/49.42
Weight	kg / lbs	3.8/8.36	3.9/8.58	3.9/8.58	4.7/10.34
Hose I.D., supply air/exhaust air	mm / in.	12 / 1/2	12 / 1/2	12 / 1/2	12 / 1/2

Performance data relate to an air pressure of 6 bar (85 PSI) and lubricated air. With oil-free operation the output will be reduced by 10 - 20%.

Optional Equipment	for motor size 7	
<b>Flange</b> incl. mounting screws	Part no.	4134632
<b>Bracket</b> incl. mounting screws	Part no.	44461738
<b>Silencer: motor operates in one direction (right or left rotation)</b>		
1 Hose nozzle	Part no.	410540 (3/8")
1 Silencer	Part no.	802671 (3/8") **
1 Silencer	Part no.	802666 (1/2") **
<b>Silencer: Motor is reversible (right or left rotation)</b>		
2 Hose nozzles	Part no.	410540 (3/8")
1 Silencer	Part no.	802666 (1/2")
<b>Maintenance unit with lubricator*</b>	Part no.	821608A
Connection thread		G 3/4
<b>Maintenance unit without lubricator*</b>	Part no.	826982A
Connection thread		G 3/4
<b>Replacement part set</b> consisting of: vanes, sealant rings, o-rings and silencers	Part no.	444787M for types 67X-747(R) to 67X-767(R) 444919D for type 67X-517(R)

\*) Maintenance unit consists of pressure regulator valve, filter and optionally with or without lubricator

\*\* the output will be reduced by approx. 10%

Of course you can also purchase individual replacement parts from us. Please contact us if this is a requirement. Our standard maintenance units are not ATEX conform. Please contact us if this is a requirement

Allowable shaft loading see page 36.

Further notes for soundproofing see page 36/37.

**Motor size 7 High torque stainless steel motors**

**Series 67X-**

reversible and right rotation

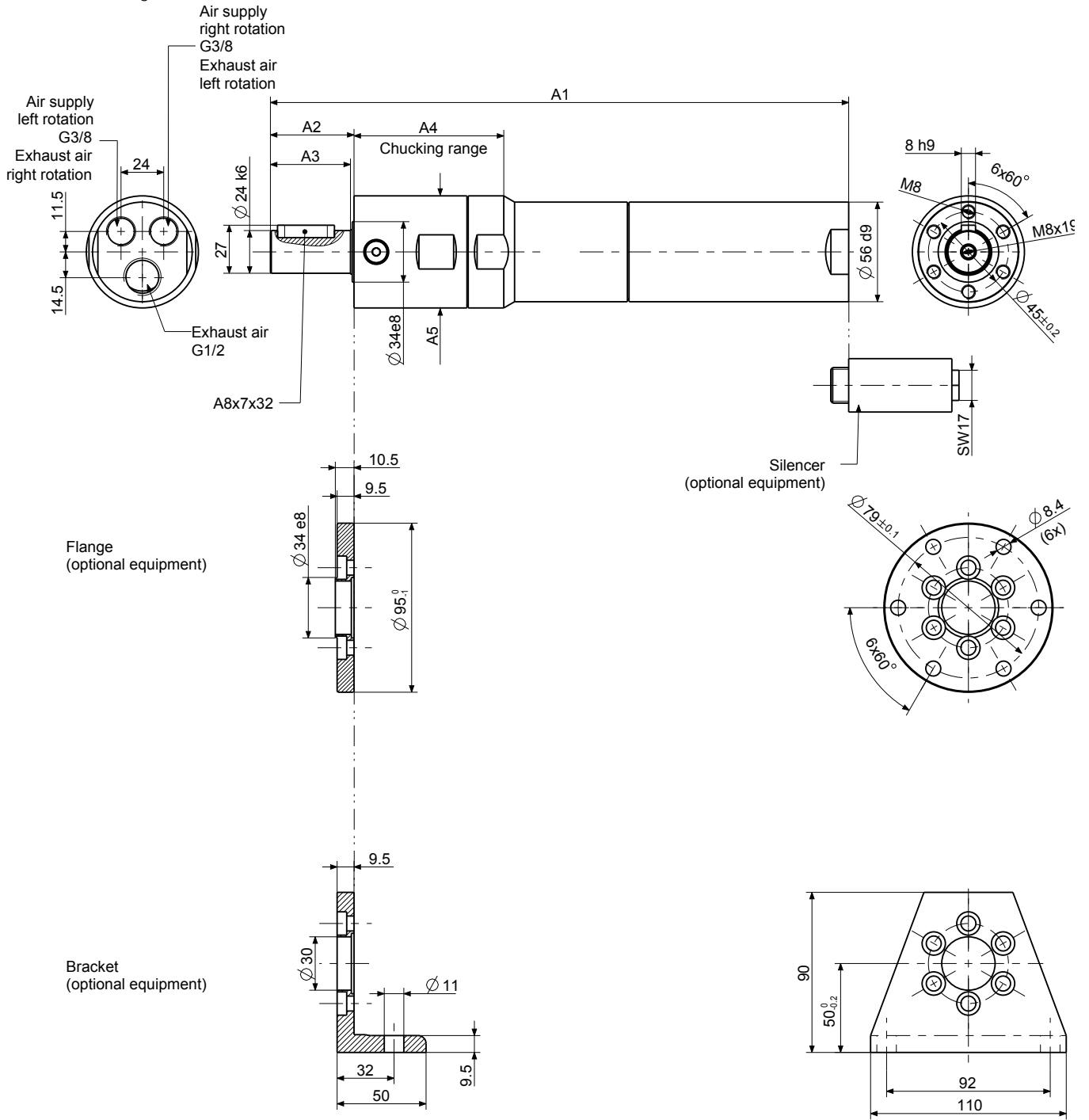



Dimensions in mm

p444338

Motor size	Series 67X- Type			Dimensions of motor (mm)				
				A1	A2	A3	A4	A5
7	67X-747	67X-757	67X-767	311.5	47	45	61	56e8
	67X-517			325	47	45	84.2	63h8

## 300/600/900 W ADVANCED LINE HIGH TORQUE AIR MOTOR with integrated holding brake

Motor size 6 with holding brake		reversible								
<b>Series 67X-</b> ATEX conform	 <b>Type</b> Part no.	<b>67X-006B</b> 1027501A	<b>67X-086B</b> 1027501N	<b>67X-016B</b> 1027501H	<b>67X-026B</b> 1027501B	<b>67X-036B</b> 1027501C	<b>67X-046B</b> 1027501D	<b>67X-056B</b> 1027501E	<b>67X-066B</b> 1027501F	<b>67X-0661B</b> 1027501G
<b>ATEX specification</b>		<b>A</b>	<b>A</b>	<b>D</b>	<b>C</b>	<b>C</b>	<b>A</b>	<b>A</b>	<b>A</b>	<b>A</b>
<b>Series 67-</b> without ATEX authorization	<b>Type</b> Part no.	<b>67-006B-1</b> 102750A	<b>67-086B-1</b> 102750N	<b>67-016B-1</b> 102750H	<b>67-026B-1</b> 102750B	<b>67-036B-1</b> 102750C	<b>67-046B-1</b> 102750D	<b>67-056B-1</b> 102750E	<b>67-066B-1</b> 102750F	<b>67-0661B-1</b> 102750G
Nominal power	W / HP	600/0.8	600/0.8	600/0.8	600/0.8	600/0.8	600/0.8	600/0.8	600/0.8	300/0.4
Nominal speed	rpm	6750	2750	2000	1500	1000	350	250	170	90
Speed (idling)	rpm	13500	5500	4000	3000	2000	700	500	340	180
Nominal torque	Nm / in.lbs	0.85/7.5	2.0/17.7	2.8/24.78	3.8/33.63	5.7/50.4	16.3/144.3	22.9/202.7	33.7/298.3	31.8/281.4
Start torque min.	Nm / in.lbs	1.25/11.06	3.1/27.4	4.3/38.06	5.7/50.4	8.5/75.2	24.5/216.8	34.3/303.6	50.6/447.8	47.7/422.15
Stall torque	Nm / in.lbs	1.6/14.16	3.9/34.5	5.4/47.8	7.2/63.7	10.8/95.6	31.1/275.2	43.5/385	64/566.4	60.4/534.54
Brake torque	Nm / in.lbs	3/26.55	7.3/64.6	10.3/91.15	13.2/116.8	20/177	58/513.3	79.2/700.9	120/1062	108/955.8
Air consumption	m <sup>3</sup> /min/cfm	0.85/30	0.85/30	0.85/30	0.85/30	0.85/30	0.85/30	0.85/30	0.85/30	0.55/30
Weight	kg / lbs	3.35/7.37	3.35/7.37	3.45/7.59	3.45/7.59	3.45/7.59	3.75/8.25	3.75/8.25	3.75/8.25	3.75/8.25
Hose I.D., supply air/exhaust air	mm / in.	12 / 1/2	12 / 1/2	12 / 1/2	12 / 1/2	12 / 1/2	12 / 1/2	12 / 1/2	12 / 1/2	12 / 1/2
Motor size 7 with holding brake		reversible								
<b>Series 67X-</b> ATEX conform	 <b>Type</b> Part no.	<b>67X-007B</b> 1030051A	<b>67X-087B</b> 1030051N	<b>67X-017B</b> 1030051H	<b>67X-027B</b> 1030051B	<b>67X-037B</b> 1030051C	<b>67X-047B</b> 1030051D	<b>67X-057B</b> 1030051E	<b>67X-067B</b> 1030051F	
<b>ATEX specification</b>		<b>A</b>	<b>A</b>	<b>D</b>	<b>C</b>	<b>C</b>	<b>A</b>	<b>A</b>	<b>A</b>	
<b>Series 67-</b> without ATEX authorization	<b>Type</b> Part no.	<b>67-007B-1</b> 103005A	<b>67-087B-1</b> 103005N	<b>67-017B-1</b> 103005H	<b>67-027B-1</b> 103005B	<b>67-037B-1</b> 103005C	<b>67-047B-1</b> 103005D	<b>67-057B-1</b> 103005E	<b>67-067B-1</b> 103005F	
Nominal power	W / HP	900/1.2	900/1.2	900/1.2	900/1.2	900/1.2	900/1.2	900/1.2	900/1.2	
Nominal speed	rpm	6300	2600	1835	1425	950	325	235	155	
Speed (idling)	rpm	12600	5200	3670	2850	1900	650	470	310	
Nominal torque	Nm / in.lbs	1.35/11.95	3.3/29.2	4.6/40.7	6.0/53.1	9.0/79.65	26.4/233.6	36.5/322.14	55.4/490.3	
Start torque min.	Nm / in.lbs	2.0/17.7	4.9/43.4	7.0/62	9.0/79.65	13.5/119.5	39.6/350.5	54.8/485	83.1/735.44	
Stall torque	Nm / in.lbs	2.6/23	6.2/54.9	8.9/78.8	11.4/101	17.1/151.3	50.2/444.3	69.4/614.2	105.3/931.9	
Brake torque	Nm / in.lbs	3/26.55	7.3/64.6	10.3/91.2	13.2/116.8	20/177	58/513.3	79.2/700.9	120/1062	
Air consumption	m <sup>3</sup> /min/cfm	1.4/49.4	1.4/49.4	1.4/49.4	1.4/49.4	1.4/49.4	1.4/49.4	1.4/49.4	1.4/49.4	
Weight	kg / lbs	3.55/7.8	3.55/7.8	3.65/8	3.65/8	3.65/8	3.95/8.7	3.95/8.7	3.95/8.7	
Hose I.D., supply air/exhaust air	mm / in.	12 / 1/2	12 / 1/2	12 / 1/2	12 / 1/2	12 / 1/2	12 / 1/2	12 / 1/2	12 / 1/2	

Performance data relate to an air pressure of 6 bar (85 PSI) and lubricated air. With oil-free operation the output will be reduced by 10 - 20%.

\*\*) the output will be reduced by approx. 10%

Optional Equipment		for motor size 6	for motor size 7
<b>Flange</b> incl. mounting screws	Part no.	4446166	4446166
<b>Bracket</b> incl. mounting screws	Part no.	4446176	4446176
<b>Silencer: motor operates in one direction (right or left rotation)</b>			
1 Hose nozzle	Part no.		410540 (G <sup>3</sup> /8)
1 Silencer	Part no.		802671 (G <sup>3</sup> /8) **)
1 Silencer	Part no.		802666 (G <sup>1</sup> /2) **)
<b>Silencer: Motor is reversible (right or left rotation)</b>			
2 Hose nozzles	Part no.		410540 (G <sup>3</sup> /8)
1 Silencer	Part no.		802666 (G <sup>1</sup> /2)
<b>Maintenance unit with lubricator*</b>	Part no.	820455A G 1/2	821608A G 3/4
<b>Maintenance unit without lubricator*</b>	Part no.	822409A G 1/2	826982A G 3/4
<b>Replacement part set</b> consisting of: vanes, sealant rings, o-rings and silencers	Part no.	444787A for part no. 102750(1)B-D 444787B for part no. 102750(1)E-F 444787H for part no. 102750(1)A, N	444919A for part no. 103005(1)B-D 444919B for part no. 103005(1)E-G 444919F for part no. 103005(1)A, N
<b>Replacement part set for brake</b> consisting of: discs, pressure spring, o-rings and silencer	Part no.	444787G	444787G

\*) Maintenance unit consists of pressure regulator valve, filter and optionally with or without lubricator

\*\*) the output will be reduced by approx. 10%

Of course you can also purchase individual replacement parts from us. Our standard maintenance units are not ATEX conform. Please contact us if this is a requirement.

Allowable shaft loading see page 36.

Further notes for soundproofing see page 36/37.

Notes to the pressure regulator valve for our ATEX conform brake motors, please find on page 38.

**Motor size 6 and Motor size 7 with holding brake, Series 67(X)-, reversible**

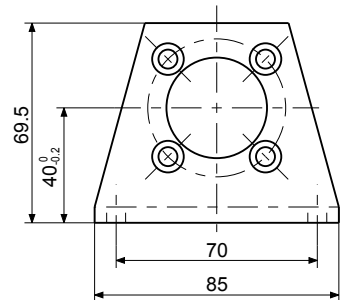
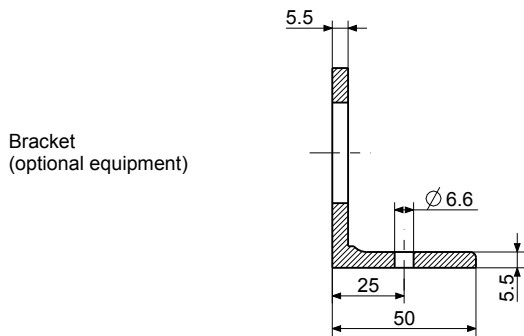
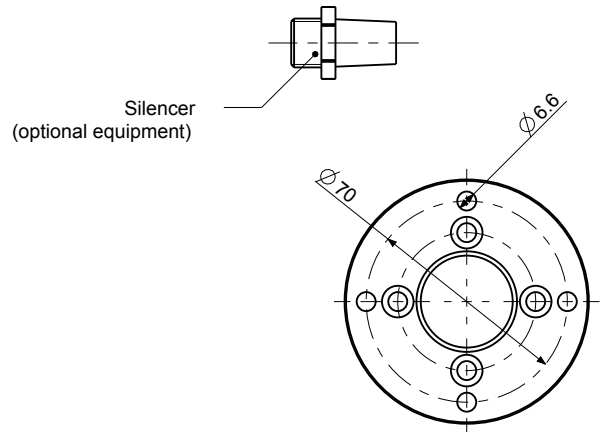
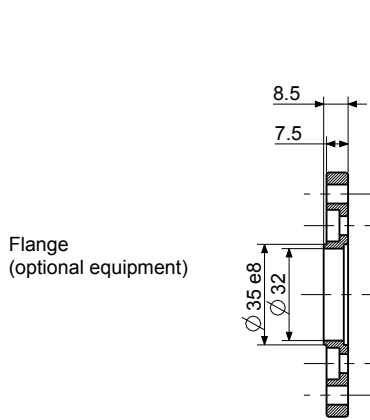
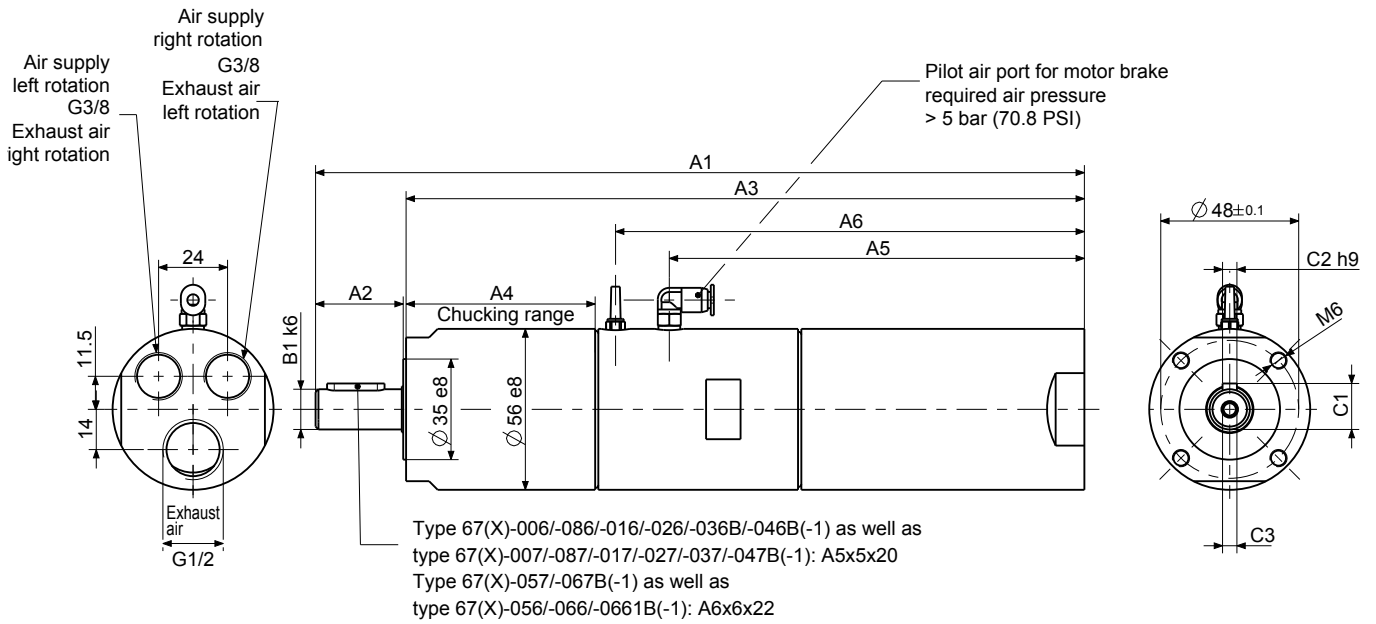

Dimensions in mm

p110531

Motor size	Series 67(X)-				Dimensions (mm)									
	Type				A1	A2	A3	A4	A5	A6	B1	C1	C2	C3
6	67(X)-006B(-1)	67(X)-016B(-1)	67(X)-026B(-1)	67(X)-036B(-1)	267.5	30	236.1	65.8	144.5	163.2	14	16	5	M5x12
	67(X)-046B(-1)	67(X)-086B(-1)			285.6		254.1	83.8						
	67(X)-056B(-1)	67(X)-066B(-1)	67(X)-0661B(-1)		287.6	35	250.5	80.4			19	21.5	6	M6x12
7	67(X)-007B(-1)	67(X)-017B(-1)	67(X)-027B(-1)	67(X)-037B(-1)	292.6	30	261.1	65.8	169.5	188.1	14	16	5	M5x12
	67(X)-047B(-1)	67(X)-087B(-1)			310.6		279.1	83.8						
	67(X)-057B(-1)	67(X)-067B(-1)			312.6	35	275.5	80.4			19	21.5	6	M6x12

## 600/900 W ADVANCED LINE HIGH TORQUE AIR MOTOR with integrated holding brake

		Motor size 6 with holding brake reversible				Motor size 7 with holding brake reversible			
Series 67X- ATEX conform	Type Part no.	67X-746B 1027501P	67X-756B 1027501R	67X-766B 1027501S	67X-516B 1027501M	67X-747B 1030051P	67X-757B 1030051R	67X-767B 1030051S	67X-517B 1030051M
ATEX specification		A				A			
Series 67- without ATEX authorization	Type Part no.	67-746B-1 102750P	67-756B-1 102750R	67-766B-1 102750S	67-516B-1 102750M	67-747B-1 103005P	67-757B-1 103005R	67-767B-1 103005S	67-517B-1 103005M
Nominal power	W / HP	600/0.8	600/0.8	600/0.8	600/0.8	900/1.2	900/1.2	900/1.2	900/1.2
Nominal speed	rpm	85	65	42	24	80	60	40	22
Speed (idling)	rpm	170	130	84	48	160	120	80	44
Nominal torque	Nm / in.lbs	67.4/596.5	88.1/779.7	136.4/1207.1	238.7/2112.5	107.4/950.5	143.2/1267.3	214.8/1901	390.6/3456.8
Start torque min.	Nm / in.lbs	101.1/894.7	132.2/1170	204.6/1810.7	358.1/3169.2	161.1/1425.7	214.8/1901	-	585.9/5185.2
Stall torque	Nm / in.lbs	128/1132.8	167.4/1481.5	259.2/2293.9	453.5/4013.5	204.1/1806.3	272.1/2408.1	-	-
Max. admissible torque	Nm / in.lbs	-	300/2655	300/2655	600/5310	-	300/2655	300/2655	600/5310
Brake torque	Nm / in.lbs	232/2053.2	-	-	-	232/2053.2	-	-	-
Air consumption	m <sup>3</sup> /min/cfm	0.85/30	0.85/30	0.85/30	0.85/30	1.4/49.42	1.4/49.42	1.4/49.42	1.4/49.42
Weight	kg / lbs	4.6/10.12	4.6/10.12	4.6/10.12	5.4/11.88	4.8/10.56	4.8/10.56	4.8/10.56	5.6/12.32
Hose I.D. supply air/exhaust air	mm / in.	12 / 1/2	12 / 1/2	12 / 1/2	12 / 1/2	12 / 1/2	12 / 1/2	12 / 1/2	12 / 1/2

Performance data relate to an air pressure of 6 bar (85 PSI) and lubricated air. With oil-free operation the output will be reduced by 10 - 20%.

Optional Equipment	for motor size 6 and 7	
<b>Flange</b> incl. mounting screws	Part no.	4134632
<b>Bracket</b> incl. mounting screws	Part no.	44461738
<b>Silencer: motor operates in one direction (right or left rotation)</b>		
1 Hose nozzle	Part no.	410540 (G <sup>3/8</sup> )
1 Silencer	Part no.	802671 (G <sup>3/8</sup> ) **)
1 Silencer	Part no.	802666 (G <sup>1/2</sup> ) **)
<b>Silencer: Motor is reversible (right or left rotation)</b>		
2 Hose nozzles	Part no.	410540 (G <sup>3/8</sup> )
1 Silencer	Part no.	802666 (G <sup>1/2</sup> )
		<b>for motor size 6</b>
<b>Maintenance unit with lubricator*</b>	Part no.	820455A
Connection thread		G 1/2
<b>Maintenance unit without lubricator*</b>	Part no.	822409A
Connection thread		G 1/2
<b>Replacement part set</b> consisting of: vanes, sealant rings, o-rings and silencers	Part no.	444787D for types 67(X)-746B(-1) to -.766B(-1) 444787E for type 67(X)-516B(-1)
<b>Replacement part set for brake</b> consisting of: discs, pressure spring and o-rings	Part no.	444787G
		<b>for motor size 7</b>
		821608A
		G 3/4
		826982A
		G 3/4
		444919C for types 67(X)-747B(-1) to -.767B(-1) 444787E for type 67(X)-517B(-1)
		444787G

\*) Maintenance unit consists of pressure regulator valve, filter and optionally with or without lubricator

\*\*) the output will be reduced by approx. 10%

Of course you can also purchase individual replacement parts from us. Our standard maintenance units are not ATEX conform. Please contact us if this is a requirement.

Allowable shaft loading see page 36.

Further notes for soundproofing see page 36/37.

Notes to the pressure regulator valve for our ATEX conform brake motors, please find on page 38.

**Motor size 6 and Motor size 7 with holding brake, Series 67(X)-, reversible**

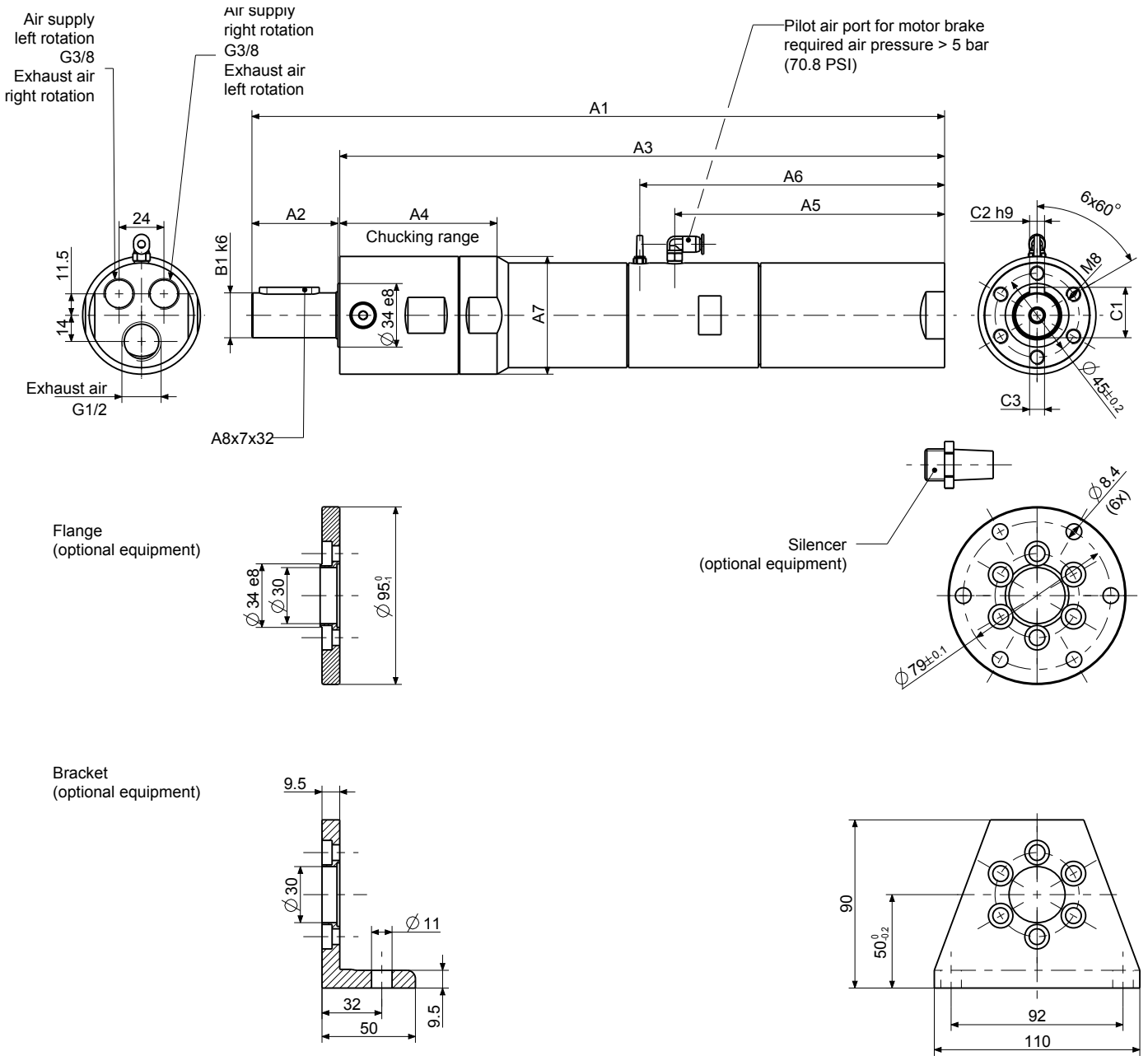

Dimensions in mm

p110532

Motor size	Series 67(X)- Type			Dimensions (mm)										
				A1	A2	A3	A4	A5	A6	A7	B1	C1	C2	C3
6	67(X)-746B(-1)	67(X)-756B(-1)	67(X)-766B(-1)	357	45	310	139.6	144.5	163.2	56e8	24	27	8	M8x12
	67(X)-516B(-1)			370.8		323.8	84.2			63h8				

Motor size	Series 67(X)- Type			Dimensions (mm)										
				A1	A2	A3	A4	A5	A6	A7	B1	C1	C2	C3
7	67(X)-747B(-1)	67(X)-757B(-1)	67(X)-767B(-1)	382.1	45	335.1	140	169.5	188.2	56e8	24	27	8	M8x12
	67(X)-517B(-1)			395.8		348.8	84.2			63h8				

## 700/1600/2200 W ADVANCED LINE AIR MOTOR

Motor size 8		reversible						
Series 67X- ATEX conform	Type Part no.	67X-008 306780A	67X-028 306780B	67X-038 306780C	67X-048 306780D	67X-058 306780E	67X-0581 306780F	67X-068 306780G
ATEX specification		A	D	C	C	C	A	A
Nominal power	W / HP	1600/2.14	1600/2.14	1600/2.14	1600/2.14	1600/2.14	700/0.9	1600/2.14
Nominal speed	rpm	4800	1250	600	350	160	100	80
Speed (idling)	rpm	9600	2500	1200	700	320	200	160
Nominal torque	Nm / in.lbs	3.1/27.4	12.2/108	25.4/224.8	43.6/385.86	95.4/844.3	66.9/592.1	191/1690
Start torque min.	Nm / in.lbs	4.7/41.6	18.3/161.95	38.2/338.07	65.4/578.79	143.2/1267.32	100/885	-
Stall torque	Nm / in.lbs	6.05/53.54	23.2/205.32	48.3/427.45	82.9/733.66	181.4/1605.39	125/1106.25	-
Max. admissible torque	Nm / in.lbs	-	-	-	-	-	-	220/1947
Air consumption	m <sup>3</sup> /min / cfm	1.6/56.48	1.6/56.48	1.6/56.48	1.6/56.48	1.6/56.48	1.1/38.83	1.6/56.48
Weight	kg / lbs	5.9/12.98	6.1/13.42	6.1/13.42	6.7/14.74	6.7/14.74	6.7/14.74	8/17.6
Hose I.D., supply air/exhaust air	mm / in.	19 / 3/4	19 / 3/4	19 / 3/4	19 / 3/4	19 / 3/4	19 / 3/4	19 / 3/4
Motor size 8		right rotation						
Series 67X- ATEX conform	Type Part no.	67X-008R 3067800A	67X-028R 3067800B	67X-038R 3067800C	67X-048R 3067800D	67X-058R 3067800E		
ATEX specification		A	D	C	C	C		
Nominal power	W / HP	2200/2.95	2200/2.95	2200/2.95	2200/2.95	2200/2.95		
Nominal speed	rpm	5000	1350	610	350	150		
Speed (idling)	rpm	10000	2700	1220	700	300		
Nominal torque	Nm / in.lbs	4.2/37.17	15.5/137.18	33.6/297.36	62/548.7	138.6/1226.61		
Start torque min.	Nm / in.lbs	6.3/55.76	23.3/206.21	50.4/446.04	93.2/824.82	207.9/1839.92		
Stall torque	Nm / in.lbs	8/70.8	29.5/261.08	63.8/464.63	118/1044.3	-		
Max. admissible torque	Nm / in.lbs	-	-	-	-	220/1947		
Air consumption	m <sup>3</sup> /min / cfm	2.1/74.13	2.1/74.13	2.1/74.13	2.1/74.13	2.1/74.13		
Weight	kg / lbs	5.9/12.98	6.1/13.42	6.1/13.42	6.7/14.74	6.7/14.74		
Hose I.D., supply air/exhaust air	mm / in.	19 / 3/4	19 / 3/4	19 / 3/4	19 / 3/4	19 / 3/4		

Performance data relate to an air pressure of 6 bar (85 PSI) and lubricated air. With oil-free operation the output will be reduced by 10 - 20%.

Optional Equipment		for motor size 8	
<b>Flange</b> incl. mounting screws	Part no.	4446272	
<b>Bracket</b> incl. mounting screws	Part no.	4446285	
<b>Silencer: motor operates in one direction (right or left rotation)</b>			
1 Hose nozzle	Part no.	410545 (1/2")	
1 Silencer	Part no.	802666 (1/2")	
1 Silencer	Part no.	822086 (3/4")	
<b>Silencer: motor is reversible (right or left rotation)</b>			
2 Hose nozzles	Part no.	410545 (1/2")	
1 Silencer	Part no.	822086 (3/4")	
<b>Maintenance unit with lubricator*</b>	Part no.	821608 A	
Connection thread		G 3/4	
<b>Maintenance unit without lubricator*</b>	Part no.	826982 A	
Connection thread		G 3/4	
<b>Replacement part set</b> consisting of:		444788A for part no. 306780(0)B-C	
vanes, sealant rings, o-rings and silencers	Part no.	444788B for part no. 306780(0)D-G	
		444788E for part no. 306780(0)A	

\* Maintenance unit consists of pressure regulator valve, filter and optionally with or without lubricator

Of course you can also purchase individual replacement parts from us. Please contact us if this is a requirement. Our standard maintenance units are not ATEX conform. Please contact us if this is a requirement

Allowable shaft loading see page 36.

Further notes for soundproofing see page 36/37.



**Motor size 8**  
**Series 67X-**  
 reversible, right rotation

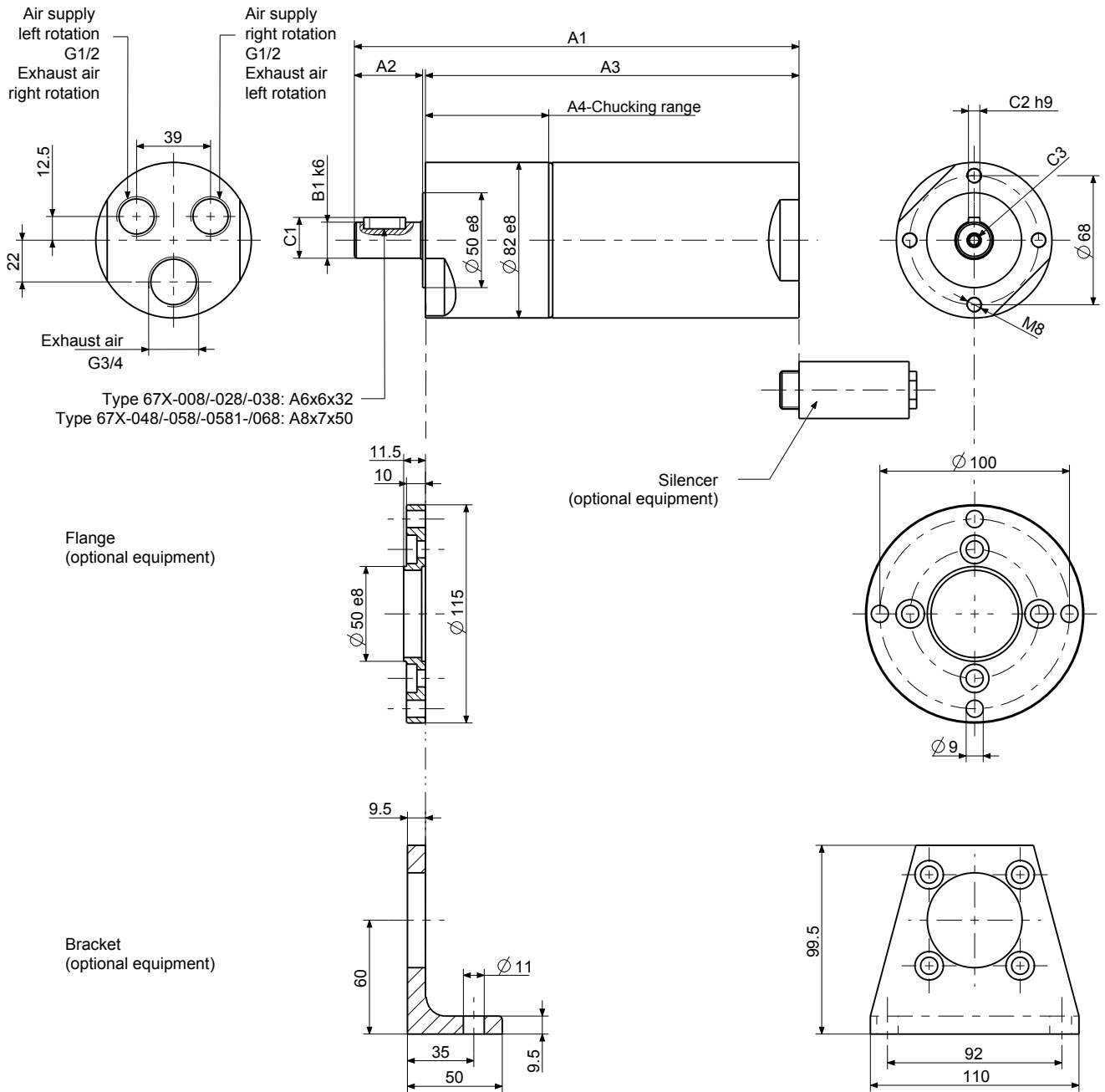

Type 67X-008/-028/-038: A6x6x32  
 Type 67X-048/-058/-0581/-068: A8x7x50

Dimensions in mm

p440236

Motor size	Series 67X- Type			Dimensions of motor (mm)							
				A1	A2	A3	A4	B1	C1	C2	C3
8	67X-008(R)	67X-028(R)	67X-038(R)	235	35	197	65	19	21.5	6	M6x15
	67X-048(R)	67X-058(R)	67X-0581	268	60	205	73	28	31	8	M10x20
	67X-068			311.5	61.5	248.5	116.5				

## 700/1600 W ADVANCED LINE AIR MOTOR with integrated holding brake

Motor size 8 with holding brake		reversible						
<b>Series 67X-</b> ATEX conform	 <b>Type</b> Part no.	<b>67X-008B</b> 1031811A	<b>67X-028B</b> 1031811B	<b>67X-038B</b> 1031811C	<b>67X-048B</b> 1031811D	<b>67X-058B</b> 1031811E	<b>67X-0581B</b> 1031811F	<b>67X-068B</b> 1031811G
<b>ATEX specification</b>		<b>A</b>	<b>D</b>	<b>C</b>	<b>C</b>	<b>C</b>	<b>A</b>	<b>A</b>
<b>Series 67-</b> without ATEX-authorization	<b>Type</b> Part no.	<b>67-008B-1</b> 103181A	<b>67-028B-1</b> 103181B	<b>67-038B-1</b> 103181C	<b>67-048B-1</b> 103181D	<b>67-058B-1</b> 103181E	<b>67-0581B-1</b> 103181F	<b>67-068B-1</b> 103181G
Nominal power	W / HP	1600/2.14	1600/2.14	1600/2.14	1600/2.14	1600/2.14	700/0.9	1600/2.14
Nominal speed	rpm	4800	1250	600	350	160	100	80
Speed (idling)	rpm	9600	2500	1200	700	320	200	160
Nominal torque	Nm / in.lbs	3.1/27.4	12.2/108	25.4/224.8	43.6/385.86	95.4/844.3	66.9/592.1	191/1690
Start torque min.	Nm / in.lbs	4.7/41.6	18.3/161.95	38.2/338.07	65.4/578.79	143.2/1267.32	100/885	-
Stall torque	Nm / in.lbs	6.05/53.54	23.2/205.32	48.3/427.45	82.9/733.66	181.4/1605.39	125/1106.25	-
Brake torque	Nm / in.lbs	8.2	30.6	66.1	121.8	-	152	-
Max. admissible torque	Nm / in.lbs	-	-	-	-	220/1947	-	220/1947
Air consumption	m <sup>3</sup> /min / cfm	1.6/56.48	1.6/56.48	1.6/56.48	1.6/56.48	1.6/56.48	1.1/38.83	1.6/56.48
Weight	kg / lbs	9/19.8	9.2/20.24	9.2/20.24	9.7/21.34	9.7/21.34	9.7/21.34	9.1/20.02
Hose I.D., supply air/exhaust air	mm / in.	19 / 3/4	19 / 3/4	19 / 3/4	19 / 3/4	19 / 3/4	19 / 3/4	19 / 3/4

Performance data relate to an air pressure of 6 bar (85 PSI) and lubricated air. With oil-free operation the output will be reduced by 10 - 20%.

Optional Equipment	for motor size 8	
<b>Flange</b> incl. mounting screws	Part no.	4446272
<b>Bracket</b> incl. mounting screws	Part no.	4446285
<b>Silencer: motor operates in one direction (right or left rotation)</b>		
1 Hose nozzle	Part no.	410545 (G <sup>1/2</sup> )
1 Silencer	Part no.	802666 (G <sup>1/2</sup> )
1 Silencer	Part no.	822086 (G <sup>3/4</sup> )
<b>Silencer: motor is reversible (right or left rotation)</b>		
2 Hose nozzles	Part no.	410545 (G <sup>1/2</sup> )
1 Silencer	Part no.	822086 (G <sup>3/4</sup> )
<b>Maintenance unit with lubricator*</b>	Part no.	821608A
Connection thread		G 3/4
<b>Maintenance unit without lubricator*</b>	Part no.	826982A
Connection thread		G 3/4
<b>Replacement part set</b> consisting of:		444788A / for part no. 103181(1)B-C
vanes, sealant rings, o-rings and silencers	Part no.	444788B / for part no. 103181(1)D-G
		444788E / for part no. 103181(1)A
<b>Replacement part set for brake</b> consisting of:		
discs, o-rings, pressure spring and silencer	Part no.	446096D

\*) Maintenance unit consists of pressure regulator valve, filter and optionally with or without lubricator

Of course you can also purchase individual replacement parts from us. Our standard maintenance units are not ATEX conform. Please contact us if this is a requirement.

Allowable shaft loading see page 36.

Further notes for soundproofing see page 36/37.

Notes to the pressure regulator valve for our ATEX conform brake motors, please find on page 38.

**Motor size 8 with holding brake**  
**Series 67(X)-**  
 reversible

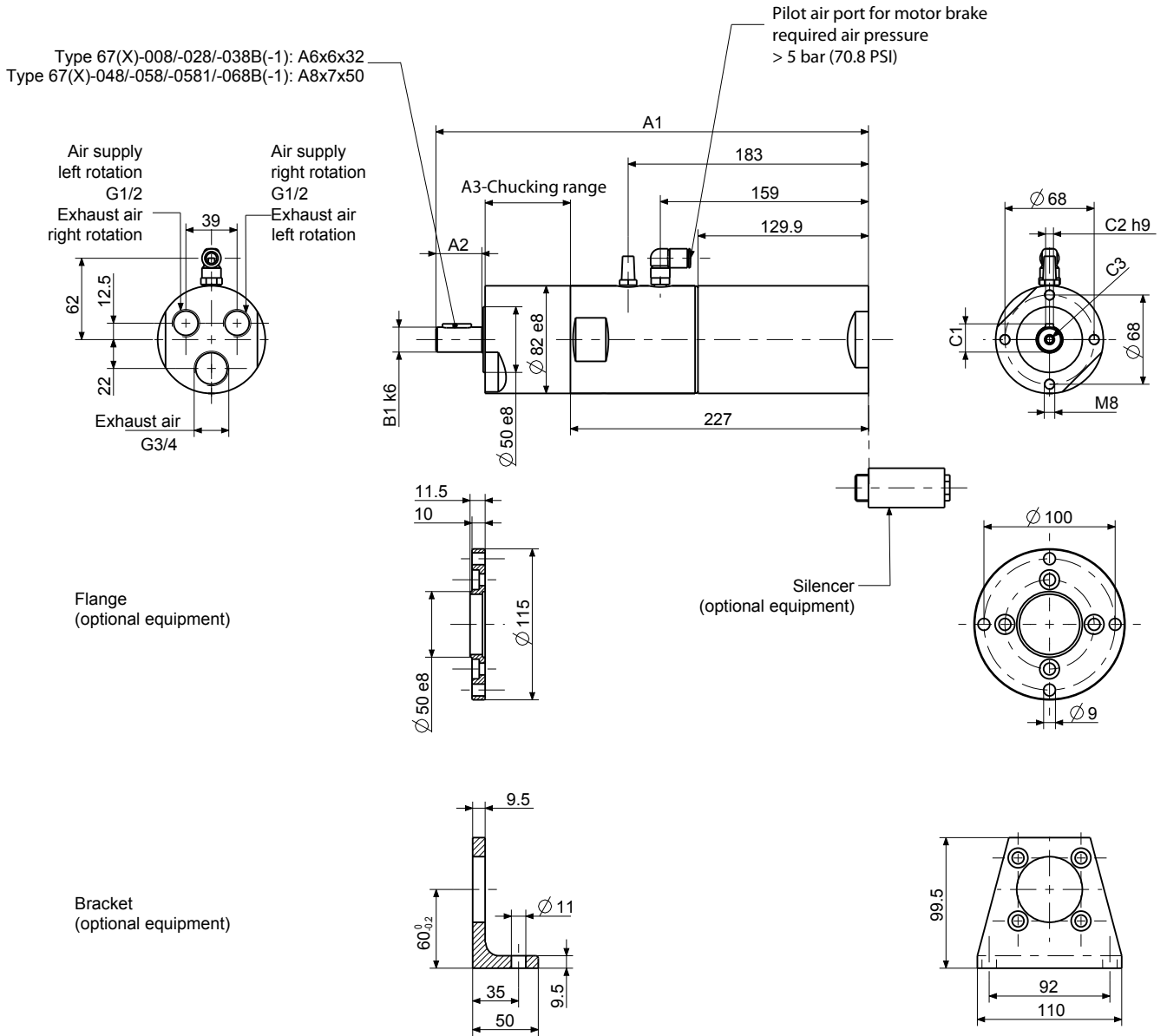

Dimensions in mm

p4401026

Motor size	Series 67(X)- with holding brake			Dimensions of motor (mm)						
	Type	Type	Type	A1	A2	A3	B1	C1	C2	C3
8	67(X)-008B(-1)	67(X)-028B(-1)	67(X)-038B(-1)	330	35	65	19	21.5	6	M6x15
	67(X)-048B(-1)	67(X)-058B(-1)	67(X)-0581B(-1)	363	60	73	28			
	67(X)-068B(-1)			406.6	63	117	31	31	8	M10x20

## Maximum allowable shaft load of the drive shaft

flattened shaft  
Motor size 0 and 1

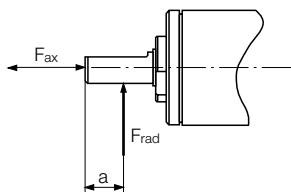

parallel key shaft  
Motor size 2 to 8

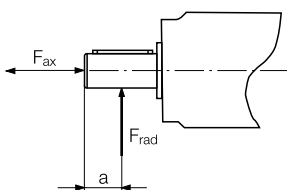

threaded shaft

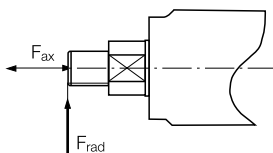

drill chuck

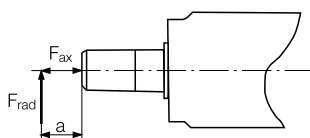

### Motors with flattened shaft

Motor size	Part no.	Fax [N]	Frad [N]	a [mm]
0	306700B-E	120	180	6
	3067000B-E			
1	306710(0)A-I	200	240	7

### Motors with parallel key shaft

Motor size	Part no.	Part no. with holding brake	Fax [N]	Frad [N]	a [mm]
2	306720(0)A-F,H		340	165	9
2.5	306725(0)A-H	107399A-H / 1073991A-H	510	1170	11
	306730(0)A-D	103029A-D / 1030291A-D			
3	306730(0)E-H,K	103029E-H,K / 1030291E-H,K	680	1040	14
	306730(0)I,L,M	103029P,R,S / 1030291P,R,S			
	306730(0)N,O	103029N,O / 1030291N,O			
6	306760(0)A-D,H,N	102750A-D,H,N / 1027501A-D,H,N	690	1190	14
	306760(0)E-G	102750E,F,G / 1027501E,F,G			
	306760(0)I,K,L	102750P,R,S / 1027501P,R,S			
	306760(0)M	102750M / 1027501M			
7	306770(0)A-D,H,N	103005A-D,H,N / 1030051A-D,H,N	690	1190	14
	306770(0)E-F	103005E,F / 1030051E,F			
	306770(0)I,K,L	103035P,R,S / 1030351P,R,S			
8	306770(0)M	103035M / 1030351M	1160	3790	20
	306780A-C,G	1031811A-C,G / 103181A-C,G			
	306780D-F	1031811D-F / 103181D-F			
	3067800A-C				
	3067800D,E		1470	2580	30

### Motors with threaded spindle

Motor size	Part no.	Fax [N]	Frad [N]	a [mm]
2	3067207A-H	340	110	0
2.5	3067257A-L	510	880	0
	3067307A-D			
	3067307E-H			
3	30673014A-D	510	860	0
	30673014E,F			
	1141327B-H			
6	1141327B-H	690	1000	0

### Motors with drill chuck

Motor size	Part no.	Fax [N]	Frad [N]	a [mm]
6	114132B-H	800	350	80

Allowable force for 10 million spindle rotations with 90 % survival probability of bearing.

## Noise level of the motors

### Noise level for motors of the series 67(X) - without or with silencer (see optional equipment)

for Motor size	Noise level dB (A) without silencer	Noise level dB (A) with silencer	Part no. silencer
0	98	85	811355
1	95	85	823236
2	99	92	823236
2.5	100	82	802675 / 802673
3	103	91	802673
6	104	94	802671 / 802666
7	106	88	802671 / 802666
8	108	95	802666 / 822086

## Use in potentially explosive environments



The correspondingly marked motors are suitable for use in potentially explosive environments.

## Silencer sets for motors of the build series 67(X)-

for Motor size	Motor operates in one turn direction R/L (clockwise or anticlockwise rotation), Part no.	Motor operates reversible U (clockwise and anticlockwise rotation), Part no.	Noise level approx. dB (A)
1	446354B	446354A	71
2	440015B	440015A	70
2,5	440016B	440016A	71
3	440018B	440018A	70
6	4400191B	4400191A	76
7	4400191B	4400191A	79
8	440020B	440020A	87

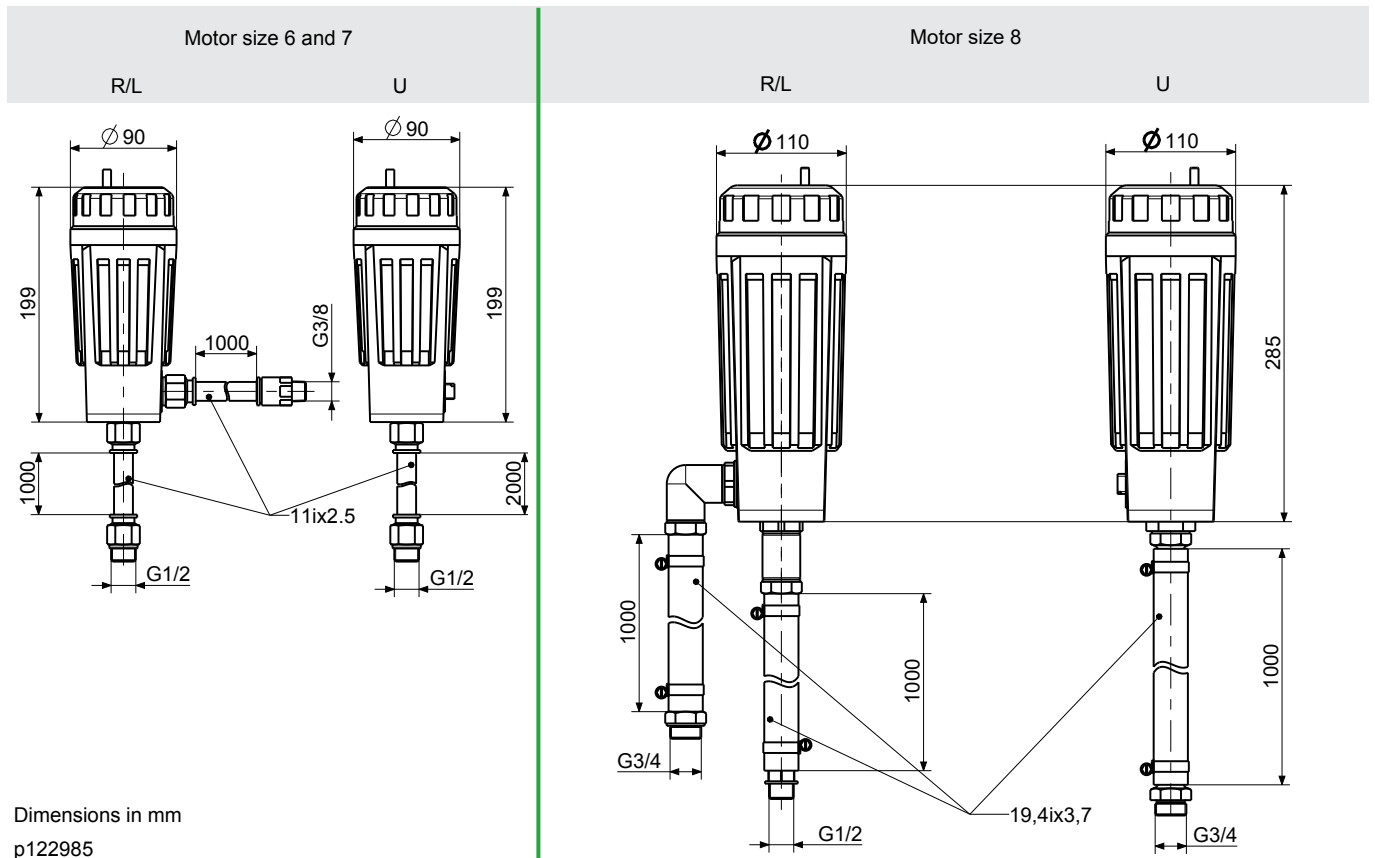
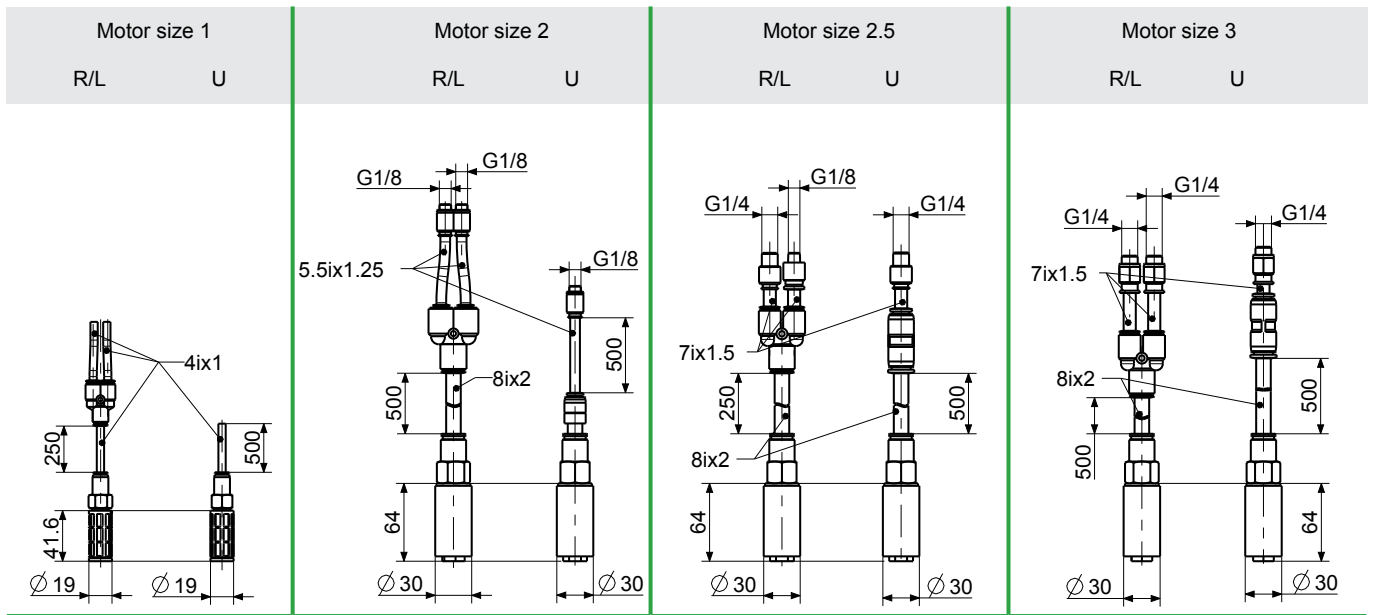

Dimensions in mm  
p122985

## Speed standard values (rpm) for HSS spiral-drills

Cutting Speed	35 m/min (115 ft./min)	28 m/min (90 ft./min)	25 m/min (80 ft./min)	14 m/min (45 ft./min)	11 m/min (35 ft./min)	7 m/min (23 ft./min)	22 m/min (70 ft./min)	12 m/min (40 ft./min)	50 m/min (165 ft./min)	90 m/min (300 ft./min)	165 m/min (540 ft./min)	210 m/min (690 ft./min)
Drill dia. mm/in.	Carbon steel			Alloy steel		Stainless steel	Cast-Iron		Copper Bronze Brass	Lightweight-Metal (common alloy mild brass <sup>1)</sup> hard		Magnesium-Alloy <sup>2)</sup>
	up to 500 N/mm <sup>2</sup> (30 long tons/sq. in.)	500 - 700 N/mm <sup>2</sup> (30 - 45 long tons/sq. in.)	above 700 N/mm <sup>2</sup> (45 long tons/sq. in.)	700 - 900 N/mm <sup>2</sup> (45 - 55 long tons/sq. in.)	900 - 1100 N/mm <sup>2</sup> (55 - 70 long tons/sq. in.)		up to 180 N/mm <sup>2</sup> (10 long tons/sq. in.)	above 180 N/mm <sup>2</sup> (10 long tons/sq. in.)				
1/0.04	11000	8800	7800	4400	3400	2200	7000	3800	16000	28000	52000	66000
2 <sup>5</sup> /64	5500	4400	3900	2200	1700	1100	3500	1900	8000	14000	26000	33000
3 <sup>1</sup> /8	3700	3000	2600	1500	1100	730	2300	1300	5300	9000	17300	22000
4 <sup>5</sup> /32	2800	2200	2000	1100	850	550	1700	950	4000	7000	13000	16500
5 <sup>13</sup> /64	2200	1800	1600	880	680	440	1400	760	3200	5600	10400	13200
6 <sup>15</sup> /64	1900	1500	1300	735	570	365	1200	630	2700	4800	8700	11000
7 <sup>9</sup> /32	1600	1300	1100	630	485	315	1000	540	2300	4000	7400	9400
8 <sup>5</sup> /16	1400	1100	975	550	425	275	875	475	2000	3500	6500	8300
9 <sup>23</sup> /64	1200	975	865	490	380	245	780	420	1800	3100	5800	7400
10 <sup>25</sup> /64	1100	880	780	440	340	220	700	380	1600	2800	5200	6600

<sup>1)</sup> Speed therefore for triplet of duro-plates, hard-paper and hard tissues, however instead of the HSS-drills we recommend quickly steel-drills equipped with hard-metal K 10

<sup>2)</sup> for thermos-plates, we recommend double the values

## Pressure regulator valve for ATEX conform brake motors

A pressure regulator valve is included within our shipment of the ATEX conform brake motors.

This safety valve turns off the air supply in the brake leads automatically when the pressure falls under 5 bar.

This prevents an irregular temperatur increase.



## The layout of your air motor:

### Calculating the motor power

$$P = \frac{M \times n}{9550}$$

**P = Power Output in kW**  
**M = Nominal-Torque in Nm**  
**n = Nominal-Speed in rpm**

The optimal working range of an air motor is close to the nominal speed. If you need lower speeds than are mentioned in the catalogue you can reduce the speed by throttling the exhaust air with only a slight loss of power. By throttling the supply air or decreasing the operating pressure the speed, torque and power are reduced.

All performance data of the DEPRAG air motors is based on operating pressure of 6 bar and the opening cross-section mentioned in the motor data. If your application conditions are different from this then you will find a comprehensive guide to the layout of our motors in brochure D6000E.

= optimal working range of the air motor

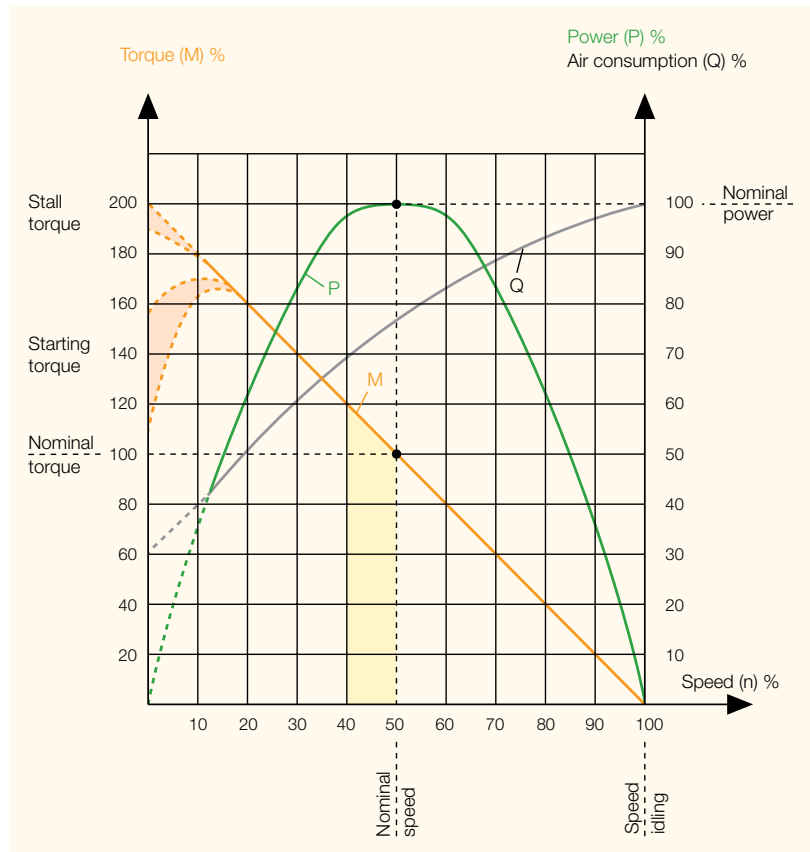

## Do you need support in selecting the right drive system?

Tell us your operational conditions and our application consultants will be happy to help:

Application:	<input type="text"/>		
In what kind of environment will the motor be installed?	ATEX requirement / explosion safety?	<input type="checkbox"/> yes	<input type="checkbox"/> no
	if yes, which safety class:	<input type="text"/>	
	food industry conformity?	<input type="checkbox"/> yes	<input type="checkbox"/> no
	sterilisable?	<input type="checkbox"/> yes	<input type="checkbox"/> no
	acid resistant?	<input type="checkbox"/> yes	<input type="checkbox"/> no
	steam resistant?	<input type="checkbox"/> yes	<input type="checkbox"/> no
Application conditions:	constant operation (24 hrs, non-stop)	<input type="checkbox"/> yes	<input type="checkbox"/> no
	duty cycle in hrs/day:	<input type="text"/>	
	days/year:	<input type="text"/>	
	cycle time (s):	<input type="text"/>	
	motor loaded to stall?	<input type="checkbox"/> yes	<input type="checkbox"/> no
	self-locking?	<input type="checkbox"/> yes	<input type="checkbox"/> no
Required turn direction:	<input type="checkbox"/> left	<input type="checkbox"/> right	<input type="checkbox"/> reversible
	(view from air inlet)		
Motor performance:	power:	<input type="text"/>	W
	nominal torque:	<input type="text"/>	Nm
	nominal speed:	<input type="text"/>	rpm
Performance influencing application conditions:	operating pressure (at motor inlet):	<input type="text"/>	bar
	operation with lubricated air possible?	<input type="checkbox"/> yes	<input type="checkbox"/> no
	smallest opening cross-section of connection pieces and hoses?	<input type="text"/>	mm
External motor design:	<input type="checkbox"/> standard steel	<input type="checkbox"/> non-corrosive	<input type="checkbox"/> aluminium
	<input type="checkbox"/> plastics	<input type="checkbox"/> ceramics	
	other:	<input type="text"/>	
Drive spindle design:	drive shaft requirements:	<input type="text"/>	
	(e. g. keyed shafts, square end, hexagonal, collet, drill chuck taper, etc.)		
	required dimensions:	<input type="text"/>	
Motor fixture design:	mounting requirements: (bracket, flange, etc.)	<input type="text"/>	
	required dimensions:	<input type="text"/>	
Additional components:	<input type="checkbox"/> holding brake	<input type="checkbox"/> operational brake	
	gear box:	<input type="text"/>	
Price range:	<input type="text"/>		
Annual requirement:	<input type="text"/>		

# DEPRAG

**DEPRAG SCHULZ GMBH u. CO.**

P.O. Box 1352, D-92203 Amberg, Germany  
Carl-Schulz-Platz 1, D-92224 Amberg  
Phone (+49) 9621 371-0, Fax (+49) 9621 371-120  
[www.deprag.com](http://www.deprag.com)  
[info@deprag.de](mailto:info@deprag.de)

CERTIFIED AS PER DIN EN ISO 9001

---